

I. Main features

- Designed specially for equipments that work in 0 ~ +999℃ , such as light industry, oven, furnace, lab equipment, cooling/heating equipments. Easy to learn and operate and lowest cost.
- Basic panel AI-207/208 is fixed with SSR or relay output modules, no need to add extra output modules.L0 or L5 modules can be added when one or two alarms is needed.
- Universal power supply 100~240VAC.
- Armed with AT and AI PID Intelligent control algorithm function.
- Qualified with ISO9001, CE,and CQC, satisfying European RoHS Standard.

II. Model Code Symbol

The type of AI-207/208 is made up of 4 parts:

AI-207	A	G	L0
Part 1 (Series)	Part 2 (Size)	Part 3 (Oupt)	Part 4 (AUX)

Part 1 stands for Model series

SS-207, standard artificial intelligence temperature controller 0.5%FS±1℃ accuracy.

1℃ display resolution.

SS-208, temperature controller 0.3%FS±1℃ accuracy. 1℃ or 0.1℃ display resolution.

Part 2 stands for Front panel dimension	Cut Out		Depth Behind Mounting Surface
Size	Front Panel width×height	width×height	
A	96×96mm	92×92mm	100mm
A1	96×96mm	92×92mm	70mm
B	160×80mm	152×76mm	100mm
B1	160×80mm	152×76mm	70mm
D	72×72mm	68×68mm	95mm
D1	48×48mm	45×45mm	78.5mm
D2	48×48mm	45×45mm	95mm
E	48×96mm	45×92mm	100mm
E1	48×96mm	45×92mm	70mm
F	96×48mm	92×45mm	100mm
F1	96×48mm	92×45mm	70mm

Part 3 indicates the module installed in OUPt socket.

L Relay contact output module (Capacity: 2A/250VAC, normal open)

G SSR voltage output module (30mA/5VDC)

Part 4 indicates Auxiliary alarm output

N (or none) no module installed

L0 Relay contact output module (Capacity: 2A/250VAC, normal open / normal close)

L5 Dual relay Output module (Capacity: 2A/250VAC, normal open, support AU1 and AU2 alarm output)

Remark: For D1-size instrument, OUPt (output module) is SSR mounted with driving voltage 30mA/5VDC. AU1 is also selectable as relay alarm output (NO+NC, 2A/250VAC). D1 is not in modular design.

III. Technical Specification

1. Input type :

Thermocouple: K, T,S,R,E, J, N,Pt100

2. Instrument Input range:

3. Measurement accuracy: 0.5%FS+1℃ (AI-207), 0.3%FS+1℃ (AI-208)

4. Control mode:

On-off control mode , or PID control with the function of parameter auto tuning.

5. SSR 5VDC/30mA output: please parallel connect SSR if more than one unit.

6. Relay contact output: 250VAC/2A,OR 30VDC/2A,open normally

7. Alarm function: High Alarm, Lower limit alarm,Deviation High Alarm.

8. Power supply voltage rating: 100-240VAC, -15%, +10% / 50-60Hz.

9. Power consumption: ≤2W.

10. Ambient temperature: -10~+60℃ , Humidity: 0~90RH%

IV. Basic display status

When powered on, it shows the basic display status, upper window displays real process value (PV) while lower window displays the set value (SV). If the real value overruns measure range(thermocouple breaks for example), upper window will display "orA" and the highest and lowest values, at this time, controller will automatically stop controlling the output.

In controller's face, basically there are four LED lights,OP1,AU1,AU2,RUN which respectively stand for output, first alarm, second alarm, and working condition.

V. Operation Description

1.Change given Set Value:

In basal display status, if the parameter lock "Loc" isn't locked, we can set setpoint (SV) by pressing \leftarrow , ∇ , \triangle . Press ∇ key to decrease the value, \triangle key to increase the value, and \leftarrow key to move to the digit expected to modify. Keep pressing \triangle or ∇ the speed of decreasing or increasing value get quick.



Press ∇ can decrease the value, press and keep pressing it can make quick decrease



Press \triangle can increase the value, press and keep pressing it can make quick increase



Press \leftarrow can change the targeted digit number of value

2. AI artificial intelligence control and auto tuning:

When AI artificial intelligence control method is chosen (Ctrl=AI), the PID parameters can be obtained by running auto-tuning. In basal display status, press \leftarrow for 2

seconds, the "At" parameter will appear. Press \triangle to change the value of "At" from "oFF" to "on", then press ∇ to activate the auto-tuning process. During auto tuning, the instrument executes on-off control. After 2-3 times of on-off action, the instrument will obtain the optimal control parameter value. If you want to escape from auto tuning status, press and hold the \leftarrow key for about 2 seconds until the "At" parameter appear again. Change "At" from "on" to "oFF", press ∇ to confirm, then the auto tuning process will be cancelled.

Note : If the setpoint is different, the parameters obtained from auto-tuning are possible different. So you'd better set setpoint to an often-used value or middle value first, and then start auto-tuning. Depending on the system, the auto-tuning time can be from several seconds to several hours.

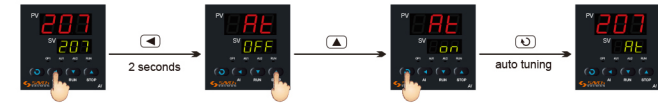

3. Parameter Setting:

In basal display status, press ∇ and hold for about 2 seconds can access Field Parameter Table. Pressing ∇ can go to the next parameter; pressing \leftarrow , ∇ , \triangle can modify a parameter. Press and hold \leftarrow can return to the preceding parameter. Press \leftarrow (don't release) and then press ∇ key simultaneously can escape from the parameter table. The instrument will escape automatically from the parameter table if no key is pressed within 30 seconds. Setting Loc=808 and then press ∇ can access System Parameter Table.



VI. Parameters and settings

Field parameter table (Press ∇ and hold for 2 seconds to access)

Code	Name	Description	Setting Range
HIA	High limit alarm	Alarm on when PV (Process Value) >HIA; alarm off when PV<HIA-AHY	0~999℃
LoA	Lower limit alarm	Alarm on when PV (Process Value) <LoA; alarm off when PV>LoA-AHY	0~999℃
HdA	Deviation high alarm	Alarm on when PV-SV>HdA; alarm off when PV-SV<HdA-AHY	0~999℃
LdA	Deviation low alarm	Alarm on when PV-SV<LdA; alarm off when PV-SV>HdA-AHY	0~999℃
Loc	Parameter Lock	Loc=0, allowed to modify parameters HIA,LoA,HdA,LdA and SV. Loc=1,not allowed to modify parameter HIA,LoA,HdA,LdA,but allow to modify SV Loc=2-3: Allowed to modify parameters HIA, LoA, HdA, But cannot change SV. Loc=4-255: NOT allowed to modify parameters and SV. Loc=808, Set to 808 and press ∇ , allowed modify all parameters.	0~255
AHY	Hysteresis	Avoid frequent alarm on-off action because of the fluctuation of PV usually sets to AHY=2	0~200

AOP	Alarm Output assignment	AOP is to define the output place of HIA,LOA,HdA as following: $AOP = \frac{C}{HdA + LdA} \frac{B}{LoA} \frac{A}{HIA}$; A.B value range is 0-2,0 or other number means never alarm. 1 and 2 means the alarms come out from AU2 and AU2. C value has below definitions: <table border="1"> <thead> <tr> <th>C</th> <th>HdA</th> <th>LdA</th> </tr> </thead> <tbody> <tr> <td>0</td> <td>-</td> <td>-</td> </tr> <tr> <td>1</td> <td>AU1</td> <td>-</td> </tr> <tr> <td>2</td> <td>AU2</td> <td>-</td> </tr> <tr> <td>5</td> <td>AU1</td> <td>AU1</td> </tr> <tr> <td>6</td> <td>AU2</td> <td>AU1</td> </tr> <tr> <td>7</td> <td>-</td> <td>AU1</td> </tr> <tr> <td>8</td> <td>-</td> <td>AU2</td> </tr> <tr> <td>9</td> <td>AU1</td> <td>AU2</td> </tr> </tbody> </table> eg:AOP=901 means , HIA ,HdA gives output from AU1,LdA from AU2.	C	HdA	LdA	0	-	-	1	AU1	-	2	AU2	-	5	AU1	AU1	6	AU2	AU1	7	-	AU1	8	-	AU2	9	AU1	AU2	0~922
		C	HdA	LdA																										
0	-	-																												
1	AU1	-																												
2	AU2	-																												
5	AU1	AU1																												
6	AU2	AU1																												
7	-	AU1																												
8	-	AU2																												
9	AU1	AU2																												
CrL	Control mode	onF : On-off control When PV=SV, output stop, When PV < SV-CHY,start output AI : AI PID control, high precision and the output time proportion can set by parameter Ctl. PID: Standard PID algorithm with anti-integral-saturation function.	AI																											
run (only for AI-208)	Running mode	Fon, running controlling status, not allow to control stop Run,running status,can press Δ into stopping status Stp, stopping status,can press ∇ into running status	Fru																											
Act	Acting method	rE:Reverse acting.Increase in measured variable causes a decrease in the output,such as heating control. dr:Direct acting.Increase in measured variable causes an increase in the output,such as refrigerating control. rEb:Reverse acting with low limit alarm and deviation low alarm blocking at the beginning of power on. drb:Direct acting with high limit alarm and deviation high alarm blocking at the beginning of power on.	rE																											
		P	Proportional band	Proportional band in PID with unit℃	1~999																									
I	Time of Integral	Time of integral in PID.No integral effect when I=0		0~999 Sec																										
d	Time of Derivative	Time of derivative in PID.No derivative effect when d=0		0~999 Sec																										
Ctl	Control period	Small value can improve control accuracy. For SSR output, generally 0.5 to 3 seconds. For Relay output, generally 15 to 40 seconds, because small value will cause the frequent On-Off of mechanical switch and shorten its service life. Ctl is recommended to be 1/4 - 1/10 of derivative time. When control under on-off control,Ctl use as restart delay time after off,for protect compressor application.		0.5~300 Sec																										

CHY	Control Hysteresis	CHY is used for on-off control, if PV > SV, output turns off; PV<SV-CHYS, output turns on.	0~200																				
InP	Input specification	<table border="1"> <thead> <tr> <th>InP</th> <th>Input spec</th> <th>InP</th> <th>Input spec</th> </tr> </thead> <tbody> <tr> <td>0</td> <td>K</td> <td>3</td> <td>T</td> </tr> <tr> <td>4</td> <td>E</td> <td>5</td> <td>J</td> </tr> <tr> <td>6</td> <td>Spare</td> <td>7</td> <td>N</td> </tr> <tr> <td>8-20</td> <td>Spare</td> <td>21</td> <td>Pt100</td> </tr> </tbody> </table>	InP	Input spec	InP	Input spec	0	K	3	T	4	E	5	J	6	Spare	7	N	8-20	Spare	21	Pt100	0~21
		InP	Input spec	InP	Input spec																		
		0	K	3	T																		
		4	E	5	J																		
		6	Spare	7	N																		
8-20	Spare	21	Pt100																				
dPt (only for AI-208)	Resolution	To choose display resolution, 0 or 0.0	0																				
Scb	Input Shift	Scb is used to make input shift to compensate the error produced by sensor or input signal. PV_after_compensation= PV_before_compensation + Scb.	-99 ~ +99																				
FIL	PV input filter	The value of FIL will determine the ability of filtering noise. When a large value is set, the measurement input is stabilized but the response speed is slow. Generally, it can be set to 1 to 3. If great interference exists, then you can increase parameter "FIL" gradually to make momentary fluctuation of measured value less than 2 to 5. When the instrument is being metrological verified, "FIL" s can be set to 0 or 1 to shorten the response time.	0~40																				
		Fru (only for AI-208)	Selection of power frequency and temperature scale	50Cmeans 50Hz,display unit is ℃。 50F,means 50Hz,display unit is ℉。 60Cmeans 60Hz,display unit is ℃。 60Fmeans 60Hz, display unit is ℉。	50C																		
SPH	Upper limit of SV	Maximum value that SV allowed to be.When SPH=400,the SV range will 0~400℃ .	0~999℃																				

VII. Installation and wiring

Wiring graph for instruments with dimension A, B, E and F:

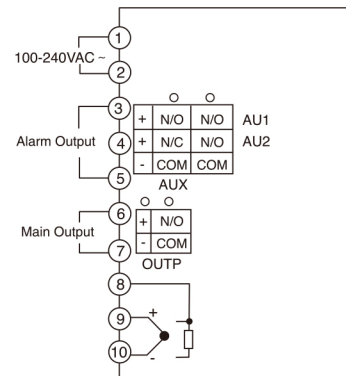

Note:The graph suits for upright instruments with dimension A or E



For instruments with dimension B or F size,just clockwise rotate the graph 90 degree.

Wiring graph for instruments with dimension A1, B1,E1 and F1:

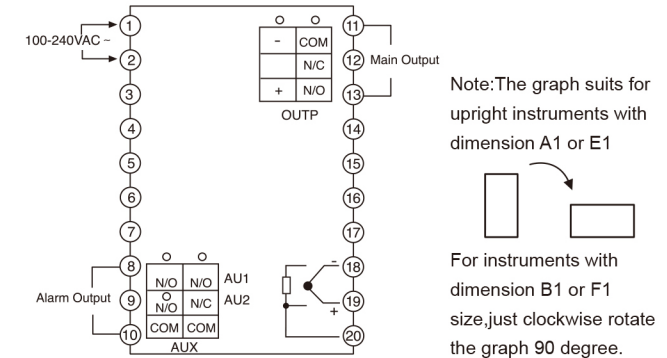

Wiring graph for D dimension(72X72mm)instruments:

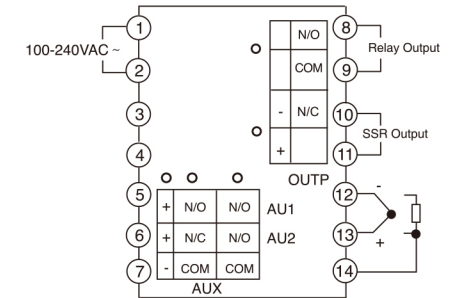

Wiring graph for D1/D2 dimension(48X48mm)instruments:

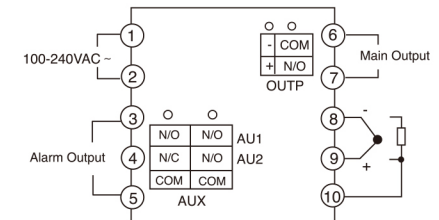

Note:

- After the connection of thermocouple with compensation wire and the cover of plastic panel, it cannot change with common wire. Pay attention to the correct connection of wire and lead.
- As CE requires, please use product that can stand over 2300V when controller is connected with extra Solid state relay.