



# CERTIFICATE

Product Model: YCB2000 Series

Standard : IEC61800

Inspector : CNC 001

Production date: Printed on the product  
or package.

This product is qualified according  
to the delivery inspection

## YCB2000 Series

High-performance vector Inverter

### OPERATION INSTRUCTION

Standard: IEC61800

CNC

CNC

Deliver  
Power For Better Life

YCB2000 Series High-performance vector Inverter

 Before installing and using this product,  
please read this manual carefully and  
pay more attention to safety.

## CNC ELECTRIC

Tel: 0086-577-61989999 Fax: 0086-577-61891122

www.cncele.com E-mail: cncele@cncele.com

# Contents

<b>1 Safety Precautions and Product Model</b>	<b>001</b>
1.1 Safety Precautions	001
1.2 VFD Series Type	002
1.3 Technical Index and Specification	003
<b>2 Installation and Wiring</b>	<b>007</b>
2.1 Operation Environment	008
2.2 Installing Direction and Space	008
2.3 Appearance and Dimension of Keypad	008
2.4 Whole Structure	009
2.5 Basic Running Wiring	011
2.6 Main Circuit Terminal Wiring	012
2.7 Schematic of The Main Circuit Terminal	012
2.8 Control Loop Terminal Function Table	014
2.9 Dial Switch	016
2.10 Wiring Notices	017
2.11 Spare Circuit	017
<b>3 Operation Panel and Operation Method</b>	
3.1 Operation Panel Keys	018
3.2 LED and Indicator Light Description	019
3.3 Monitoring Parameter Display	019
3.4 Run Status Parameter Display	020
3.5 Malfunction Alarm Display	020
3.6 Function Code Editing Display	021
3.7 Monitoring Parameter	021
3.8 Function Code Setting	022
3.9 User Password Setting and Function Code Edit	023

<b>4 Function Parameter Table and Description</b>	<b>025</b>
4.0 Monitoring Parameter Group and Fault Record	025
4.1 Function Code	029
4.2 Detailed Function Description	076
<b>5 Communication Protocol</b>	<b>079</b>
5.1 RTU mode and format	079
5.2 Register Address and Function Code	079
5.3 Functions of other Register Address	089
5.4 Fault Code	090
5.5 Pre-alarm Code of the Driver	091
5.6 Control Command Format (see function code 06H example)	091
5.7 Parameter Attribute	092
5.8 Error Code from Slave Response of Abnormal Information	092
5.9 Communication Address of all Parameters	093
<b>6 Troubleshooting</b>	<b>094</b>
6.1 Fault information and Troubleshooting	094
6.2 Abnormal Phenomena Solution	098
<b>7 Maintenance</b>	<b>100</b>
7.1 Routine Maintenance	100
7.2 Periodic Maintenance	100
<b>Appendix</b>	<b>102</b>
Appendix 1: Parameters for Photovoltaic Pumps Special Use	102
Appendix 2: 600 Series Guide for Rapid Debugging of Constant-pressure Water Supply	104
Appendix 3: 610 Series Guide for Rapid Debugging of CNC Machine	105

# 1 Safety Precautions and Product Model

## 1.1 Safety Precautions

- ◇ Do not install this equipment in an explosive gas atmosphere, or there will be explosion hazards.
- ◇ Only qualified individuals should proceed with wiring, or there will be electric shock hazards. Do not conduct any wiring during the system power on to avoid the electric shock
- ◇ Do not touch control terminals, internal circuit board and its components, or there will be electric shock hazard.
- ◇ Earth terminal must be exactly grounded when using inverter. Grounding must be confirmed with the national electric safety regulation and other electric code.
- ◇ After power off, do not touch internal circuit board or any parts inside within 5 minutes after keypad display went off. Any internal operation must be after making sure of discharge off with instrument checking to avoid the electric shock.
- ◇ Do not connect AC power to output terminal (U, V, W) of inverter. The only terminal the AC power allowed to be connected is R, S, T (or LI, L2 single-pharse source inverter).
- ◇ Static electricity on human body can damage MOS device. Do not touch PCB and IGBT without anti-static measure.
- ◇ Do not lose screws, spacers and other metallic foreign bodies inside the driver to avoid fire hazard and driver damage.
- ◇ Do not connect 220V AC power to internal control terminal of the driver, or there will be serious damage to the driver.
- ◇ If overcurrent protection occurs afier start the driver, confirm again the external wiring and then power on and run the driver.
- ◇ Do not switch off the power to stop the driver. Cut off power source after the motor stops running.
- ◇ Do not install the driver in places with direct sunlight.

## 1.2 VFD Series Type

Input Voltage	Rated Power(KW)	Rated Output Current (A)	Adapted Motor
Single Phase 230V±15%	0.75	5	0.75
	1.5	7	1.5
	2.2	10	2.2
Three Phase 380V±15%	0.75	2.5	0.75
	1.5	3.7	1.5
	2.2	5	2.2
	4.0/5.5	9.0/13	4.0/5.5
	5.5/7.5	13/17	5.5/7.5
	7.5/11.0	17/25	7.5/11.0
	11.0/15.0	25/32	11.0/15.0
	15.0/18.5	32/37	15.0/18.5
	18.5/22.0	37/45	18.5/22.0
	22.0/30.0	45/60	22.0/30.0
	30.0/37.0	60/75	30.0/37.0
	37.0/45.0	75/90	37.0/45.0
	45.0/55.0	90/110	45.0/55.0
	55.0/75.0	110/150	55.0/75.0
	75.0/90.0	150/176	75.0/90.0
90.0/110.0	176/210	90.0/110.0	
110.0/132.0	210/250	110.0/132.0	
132.0/160.0	250/300	132.0/160.0	
160.0/185.0	300/340	160.0/185.0	
185.0/200.0	340/380	185.0/200.0	

## 1.2 VFD Series Type

Input Voltage	Rated Power(KW)	Rated Output Current (A)	Adapted Motor
Three Phase 380V±15%	200.0/220.0	380/415	200.0/220.0
	220.0/250.0	415/470	220.0/250.0
	250.0/280.0	470/520	250.0/280.0
	280.0/315.0	520/600	280.0/315.0
	315.0/350.0	600/640	315.0/350.0
	350	640	350
	400	690	400
	500	860	500

## 1.3 Technical Index and Specification

Input	Rated Voltage, Frequency	3-phase (4T#series) 380V;50/60HZ 1-phase (2S#series) 220V;50/60HZ	
	Allowed Voltage Range	3-phase (4T#series) 320V ~ 460V 1-phase (2S#series) 160V ~ 260V	
Output	Voltage	4T#series; 0 ~ 460V 2S#series; 0 ~ 260V	
	Frequency	Low frequency mode: 0 ~ 300HZ ; High frequency mode: 0 ~ 3000HZ	
	Overload Capacity	G type: 110% for long-term, 150% for 1 min, 180% for 5s P type: 105% for long-term, 120% for 1 min, 150% for 1s	
Control Mode		V/F control, advanced V/F control, V/F separation control, electric current vector control	
Control Character	Frequency Setting Resolution	Analog Input	0.1% of maximum output frequency
		Digital Setting	0.01 Hz

## 1.3 Technical Index and Specification

Control Character	Frequency Precision	Analog Input	Within 0.2% of maximum output frequency
		Digital Setting	Within 0.01% of set output frequency
	V/F Control	V/F Curve (voltage frequency character)	Reference frequency setting 5 ~ 600 Hz, multipoint V/F curve setting, or fixed curve of constant torque, low decreasing torque 1, low decreasing torque 2, square torque
		Torque Compensation	Manual setting: 0.0 ~ 30% of rated output Automatic compensation: according to output current and motor parameter
		Automatic Current-limiting and Voltage-limiting	During acceleration, deceleration or steady running, detect automatically the current and voltage of motor stator, and control it within bounds based on unique algorithm, minimize fault-trip chance
	Senseless Vector Control	Voltage Frequency Character	Adjust pressure/frequency ratio according to motor parameter and unique algorithm
		Torque Character	Starting torque: 3.0 Hz 150% rated torque (VF control) 0.5 Hz 180% rated torque (SVC, FVC) 0.05 Hz 180% rated torque (VC) Operating speed precision in steady state: ≤ +0.5% rated synchronous speed Torque response: ≤ 50ms VC, SVC, FVC ≤ 20ms
		Motor Parameter Self-measurement	Being able to detect parameter automatically under static state and dynamic state of motor, thus guarantee an optimum control.
		Current and Voltage Restrain	Current closed-loop control, free from current impact, perfect restrain function of overcurrent and overvoltage
	Undervoltage Restrain during Running	Specially for users with a low or unsteady voltage power grid: even lower than the allowable voltage range, the system can maintain the longest possible operating time based on its unique algorithm and residual energy allocation strategy	



### 1.3 Technical Index and Specification

Typical function	Multi-velocity and Traverse Operation	16 segments programmable multi-velocity control, multiple operation mode. Traverse operation: preset frequency and center frequency adjustable, parameter memory and recovery after power cut.		
	PID Control R5485 Communication	Built-in PID controller (able to preset frequency). Standard configuration RS485 communication function, multiple communication protocol for choice, synchronizing control function.		
	Frequency Setting	Analog Input	Direct voltage 0 ~ 10V, direct current 0 ~ 20mA (optional up limit and lower limit)	
		Digital Input	Operation panel setting, RS485 port setting, UP/DW terminal control, or combined with analog input	
	Output Signal	Digital Input	2 channel OC output and one channel relay output (TA, TB, TC), up to 16 choices	
		Analog Input	2 channel analog signal output, output ranging within 0 ~ 20mA or 0 ~ 10V with flexibly setting, achievable output of physical quantities like set frequency, output frequency	
	Automatic Steady-voltage Operation	Dynamic steady state, static steady state, and unsteady voltage for choices to obtain the steadiest operation		
	Acceleration and Deceleration Time Setting	0.1s ~ 3600min continuous setting, S type and linear type mode for choice		
	Brake	Dynamic Braking	Dynamic braking initial voltage, backlash voltage and dynamic braking continuous adjustable	
		DC Braking	Halt DC braking initial frequency: 0.00 ~ [F0.16] upper limit frequency Braking time: 0.0 ~ 100.0s; Braking current: 0.0% ~ 150.0% of rated current	
Flux Restraint		0 ~ 100 0: invalid		

### 1.3 Technical Index and Specification

Typical function	Low Noise Running	Carrier frequency 1.0kHz ~ 16.0kHz continuous adjustable, minimize motor noise	
	Speed Tracking and Restart Function	Smooth restart during operation, instantaneous stop and restart	
	Counter	A built-in counter, facilitate system integration	
Display	Operation Panel Display	Running State	Output frequency, output current, output voltage, motor speed, set frequency, module temperature, PID setting, feedback, analog input and output.
		Alarm	The latest 6 faults record; running parameters record when the latest fault tripping happens including output frequency, set frequency, output current, output voltage, DC voltage and module temperature.
Protective Function			Overcurrent, overvoltage, undervoltage, module fault, electric thermal relay, overheat, short circuit, default phase of input and output, motor parameter adjustment abnormality, internal memory fault, etc.
Environment	Ambient Temperature		-10°C ~ +4 0°C (please run the VFD in derated capacity when ambient temperature is 40°C ~ 50°C )
	Ambient Humidity		5% ~ 95%RH, without condensing drops
	Surroundings		Indoors (without direct sunlight, corrosive or flammable gas, oil fog and dust)
Structure	Altitude		Running in derated capacity above 1000m, derate 10% for every 1000m rise.
	Protection Level	IP20	
Cooling Method		Air cooling with fan control	
Installation Method			Wall-hanging type, cabinet type

## 2 Installation and wiring

### Danger

- ◇ Ensure the power has been cut off before wiring.  
Electric shock and fire hazard.
- ◇ Ask electric engineering professionals to conduct wiring.  
Electric shock and fire hazard.
- ◇ Earth terminals must be reliably grounded.  
(380V class: especially the third grounding)  
Electric shock and fire hazard.
- ◇ Check if its action is effective after emergency brake terminal is connected.  
Injury risk (wiring responsibility should be borne by users).
- ◇ Do not touch output terminals directly. The output terminal is connected directly to motor. There should be no short circuit between output terminals.  
Electric shock and short circuit hazard.
- ◇ Install the terminal cover before power on, and ensure power off when dismantling the terminal cover.  
Electric shock hazard.
- ◇ Conduct check and maintenance after 5 ~ 8 minutes after power off when internal residual electricity is discharged completely.  
Hazard of residual voltage in electrolytic capacitor.

### Caution

- ◇ Check if the voltage of power inlet wire agrees with rated input voltage of VFD.  
Injury and fire hazard.
- ◇ Connect brake resistor or brake unit according to wiring diagram.  
Fire hazard.
- ◇ Choose screw driver and wrench with specified torque to fasten terminals.  
Fire hazard.
- ◇ Do not connect the power input wire to output U, V, W terminals.  
It will cause internal damage to VFD if load the voltage on output terminals.
- ◇ Do not dismantle the front panel cover, only the terminal cover needs to be dismantled when wiring.  
It may cause internal damage to VFD.

## 2.1 Operation Environment

- ◇ No corrosive gases, vapors, dust or oily dust, no direct sunlight.
- ◇ No floating dust and metal particle.
- ◇ Ambient humidity 20% ~ 90% RH.
- ◇ Vibration less than 5.9m/s<sup>2</sup>(0.6g).
- ◇ No electromagnetic interference.
- ◇ Ambient temperature -10°C ~ 40°C . Ensure good ventilation when ambient temperature exceeds 40°C .
- ◇ Use electric cabinet or remote control method in non-standard operation environment and ensure good ventilation and heat dissipation. The service life of VFD lies in installing environment and operation condition. But even in standard environment, a long-term continuous running can guarantee a life of no more than 5 years for electrolytic capacitor and about 3 years for cooling fan. An update or a thorough maintenance in advance is recommended.

## 2.2 Installing Direction and Space

To ensure a good cooling cycle, the VFD must be installed vertically, and keep enough space from surroundings.

## 2.3 Appearance and Dimension of Keypad

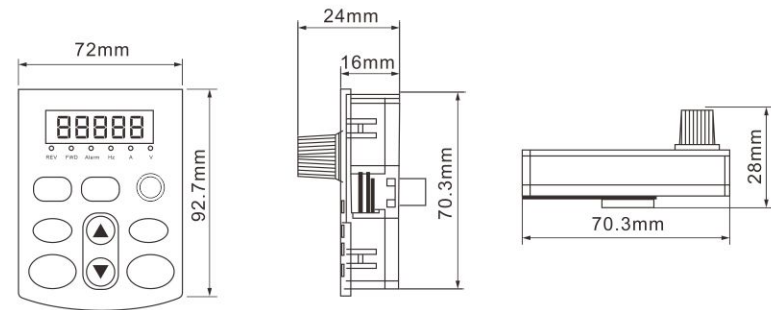

## 2.4 Whole Structure

The main technical parameters

Power (kw)	Installation size		Outline size			Mounting hole size (mm)	Note
	A(mm)	B(mm)	H(mm)	W(mm)	D(mm)		
0.75 ~ 2.2	115	175	185	125	160	4	—
4.0 ~ 7.5	136	230	246	150	176	5	—
11 ~ 18.5	201	306	320	218	215	5	—
22	150	404	420	235	210	6.5	—
30 ~ 37	195	433	460	270	220	8	—
45 ~ 55	240	537	565	320	275	8	—
75 ~ 110	274	642	670	380	272	8	—
132 ~ 160	—	—	—	—	—	—	—
185 ~ 220	—	—	—	—	—	—	—
250 ~ 350	—	—	—	—	—	—	—

Dimensions

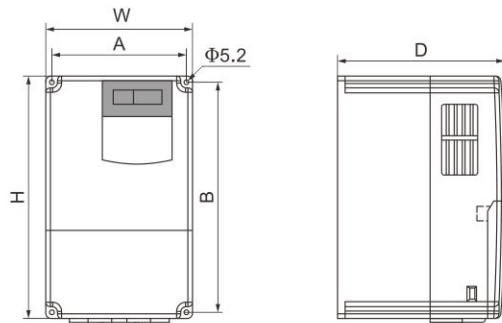

Figure A-1 Outline size for 7.5KW and below models(380V)

Dimensions

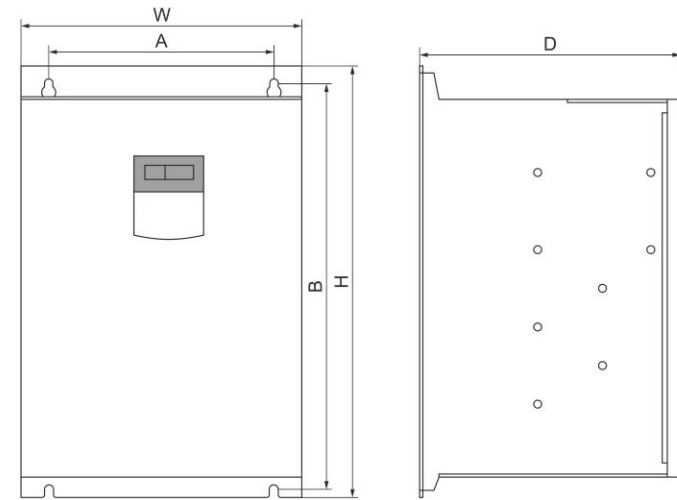

Figure A-2 Outline size for 11 ~ 110KW model(380V)

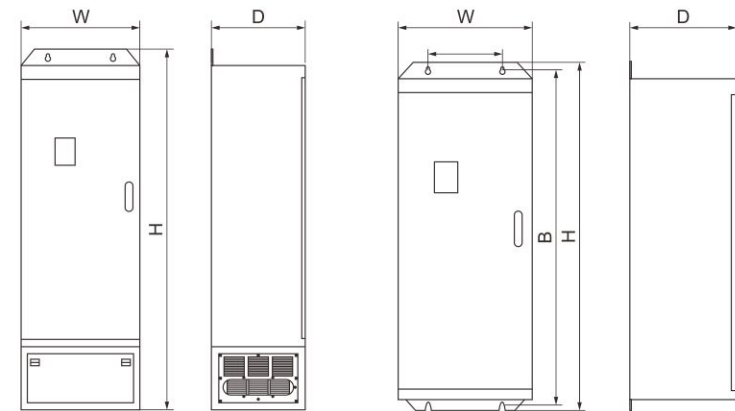
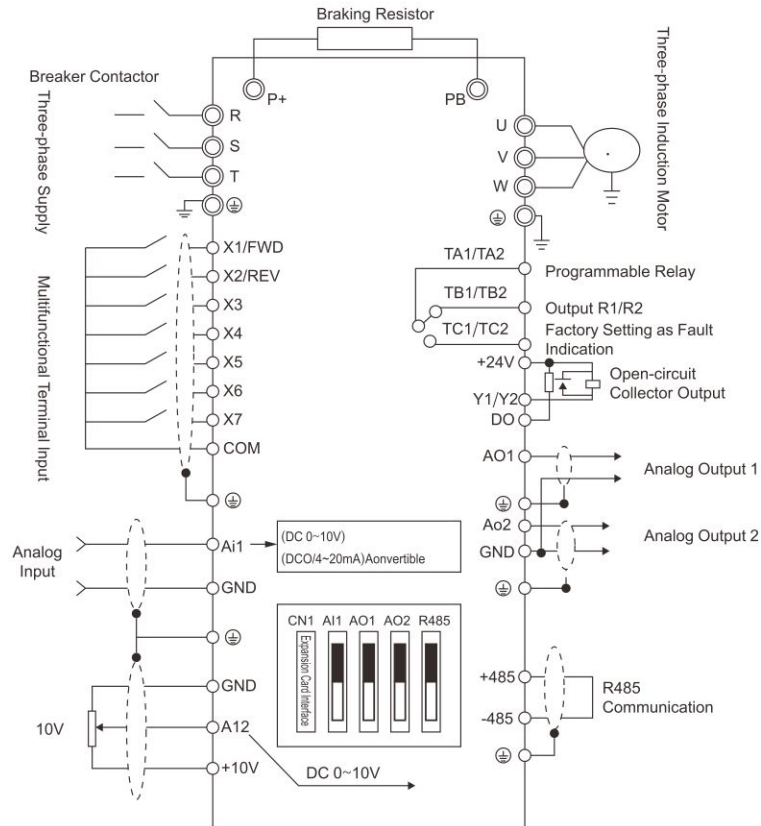

Figure A-3 Outline size for 160 ~ 350KW model(with base and without base 380V)

## 2.5 Basic Running Wiring

The wiring parts of VFD include major loop and control loop. Open the cover of I/O terminals, users can see the major loop terminal and control loop terminal, and must conduct the wiring according to the following diagram.



## 2.6 Main Circuit Terminal Wiring

Single phase 220V:

Three phase 380V:

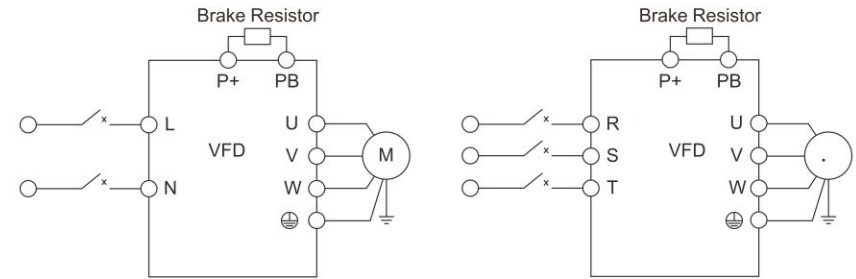

## 2.7 Schematic of The Main Circuit Terminal

Single phase 220V:

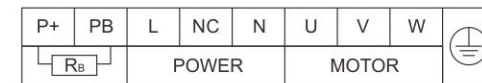

(0.75kW~2.2kW)

Terminal	Function
L, N	Single phase 220V AC power supply input terminal
P+, PB	External brake resistor reserved terminal
P-	DC negative bus output terminal
U, V, W	Three phase AC output terminal
⊕、E	Ground terminal



## 2.7 Schematic of The Main Circuit Terminal

Three phase 380V:

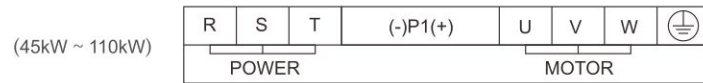
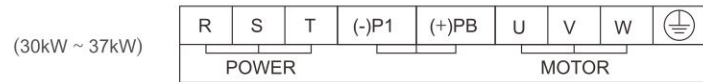
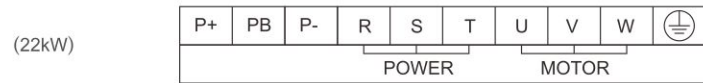
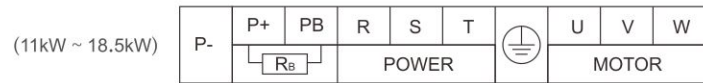
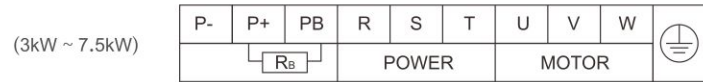
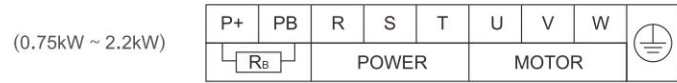

Terminal	Function
R, S, T	Three phase power supply input terminal
(+), (-)	External brake unit reserved terminal
P+, PB	External brake resistor reserved terminal
P, P+	External DC reactor reserved terminal
(-)	DC negative bus output terminal
U, V, W	Three phase AC output terminal
⊕, E	Ground terminal

## 2.8 Control Loop Terminal Function Table

Functional Specification of Control Loop Terminal			
Category	Terminal Number	Functions	Specification
Multi-functional Digital Input Terminal	FWD	Effective when short circuit between(FWD, REV, X3, X4, X5, X6, X7) ~ COM, and the functions are set by parameters F7.00 ~ F7.06 (common port: COM)	INPUT, 0 ~ 24V level signal, low level effective, 5mA.
	REV		
	X3		
	X4		
	X5		
	X6		
Digital Output Terminal	X7	X7 can work as one of the multi-functional terminals, also as high-speed pulse input terminal with programming, see F7.06.	
	Y1	Multi-functional programmable collector open circuit output channel 2, can be programmed as DO terminal of various functions (common port: COM)	OUTPUT, maximum load current ≤ 50mA.
	Y2		
Analog Input/Output Terminal	DO	Can be programmed as impulse output terminal of various functions as many as 13 kinds (common port: COM). See F6.23.	OUTPUT, output frequency range F6.32 ~ F6.35, set maximum frequency as high as 50KHz.
	AI1	All receives voltage/current input. Jumper JP3 (for jumper terminal AI1) can select voltage or current input mode, and voltage input is the default one. For current input, just short the middle and another pin with the jumper cap. AI 2 only receives voltage input. Measuring range setting is function code F6.00 ~ F6.11. (reference ground: GND)	INPUT, input voltage range: 0 ~ 1 0V (input impedance: 100KΩ), input current range 0 ~ 20mA (input impedance: 500Ω).
AI2			

## 2.8 Control Loop Terminal Function Table

Functional Specification of Control Loop Terminal			
Category	Terminal Number	Functions	Specification
Analog Input/Output Terminal	AO1	AO1 is able to output analog voltage/current (total 13 kinds of signals). Jumper Jp4 (for jumper terminal AO1) can select volt age or current output mode, and voltage output is the default one. For current output, just short the middle and another pin with the jumper cap. AO2 Outputs analog voltage/current. The output voltage and current are selected by the jumper JP6(AO2 jumper). See function code for details, F6.21, F6.22.(Reference ground: GND)	OUTPUT, 0 ~1 0VDC voltage. Output voltage of AO1, AO2 came from PMW waveform of CPU. Output voltage is in direct proportion to the width of PWM waveform.
	AO2		
Relay Output Terminal	TA1/TA2	Two-channel programmable relay output terminal, TA1/TA2, TB1/TB2, TC1/TC2 as many as 99 kinds. See F7.20.	TA-TB: normal close; TA-TC: normal open. Contact compacity: 250VAC/2A (COSΦ =1); 250VAC/1A(COS Φ =0.4), 30VDC/1A.
	TB1/TB2		
	TC1/TC2		
Power Port	+10V -GND	Provide external +10v power supply, which is generally used as the working power supply of the external potentiometer. The resistance range of the potentiometer is 1 KΩ ~ 5 KΩ	Max output current 10mA
	+24V -COM	Provide external +24v, which is generally used as power supply of the digital input and output terminal and external sensor.	Max output current 200mA
Communication Port	A+/B-	RS485 communication port	Input and output signal terminal of MODBUS-RTU protocol communication

- ◇ Control terminal All can input both voltage and current signal, while A12 can only input voltage signal; users can conduct corresponding jumper on master control board according to signal type.
- ◇ Connecting weak analog signal is easily affected by external disturbance. So wiring should be as short as possible. The external control line should be set with isolating device or shielding line, and should be grounded.
- ◇ Input order signal line and frequency meter should be wired separately with shielding, and away from major loop wiring.
- ◇ Control loop wiring should be over 0.75 mm<sup>2</sup>, and STP (shielded twisted pair) is recommended. The connecting part of control loop terminals should be enameled with tin, or process metal joint with cold pressing.
- ◇ While connecting analog signal output devices, malfunction may occur because of interference from VFD, which can be solved by fixing with capacitor or ferrite bead to the analog signal output device.

## 2.9 Dial Switch

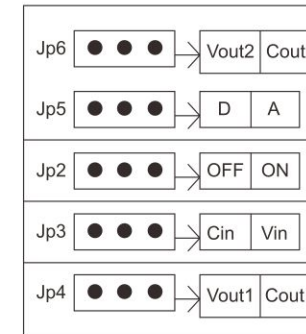

JP5	
A	A of A/D is effective, output voltage signal
D	D of A/D is effective, output pulse signal
JP2	
OFF	Non-connecting for matched resistance of 485 communication
ON	Connecting for matched resistance of 485 communication
JP3	
Cin	AI1 input current signal
Vin	AI1 input voltage signal
JP4	
Vout1	AO1 output voltage signal
Cout1	AO1 output current signal
JP6	
Vout2	AO2 Output current signal
Cout2	AO2 Output voltage signal

## 2.10 Wiring Notices









- ◇ Cut of the input power of VFD while dismantling and changing the motor.
- ◇ Switching of motor or work frequency power supply should only be conducted when the VFD stops output.
- ◇ To reduce the effect of EMI (electromagnetic interference), add a surge absorber when electromagnetic connector and relay are close to VFD.
- ◇ Do not connect AC input power to output terminal U, V, W of VFD.
- ◇ Add an isolating device to the external control line or use shield line.
- ◇ Input order signal line should be wired separately with shielding, and away from major loop wiring.
- ◇ When carrier frequency is less than 4kHz, keep the distance between VFD and motor within 50m; when carrier frequency exceeds 4kHz, make an appropriate reduction of the distance, and better lay the wire in metal tube.
- ◇ When adding peripherals (filters, reactors, etc.) to the VFD, check the ground resistance with 1000V megger and ensure the value is above 4MΩ.
- ◇ Do not add phase advance capacitor or RC snubber to the U, V, W terminal of VFD.
- ◇ If the VFD starts frequently, do not cut of the power, use the COM/RUN of control terminal to conduct start and stop so as not to damage the rectifier bridge.
- ◇ The earth terminal must be grounded reliably (grounding impedance should be under 100Ω) to avoid accidents, or there might be electric leakage.
- ◇ Choose the wire diameter according to national electrical code while conducting major loop wiring.

## 2.11 Spare Circuit

It may cause big downtime loss or other accidental failure during VFD failure or tripping. Adding spare circuit is recommended under this circumstance to ensure safety. Note: confirm and test the operation characteristic of the spare circuit in advance to ensure the working frequency and the phase sequence of converted frequency are agreed.

## 3 Operation Panel and Operation Method

### 3.1 Operation Panel Keys

Key	Name	Function Description
	Programming /escape key	Enter or escape from programming
	Shift/monitor key	Choose the bit of the data which is to be set and modified when the VFD is in edit status; switch monitor parameter to be shown when the VFD is in other modes.
	Enter key	Enter into sub-menu items or confirm data.
	Function key	According to the setting of function parameter FE.01, jog or reverse run, and frequency clearance is available when pressing this key under keypad mode.
	Run key	Enter into run mode under keypad model.
	Stop/reset key	In common run status the VFD will be stopped according to set mode after press this key if run command channel is set as keyboard stop effective mode. The VFD will be reset and resume normal stop status after pressing this key when the VFD is in malfunction status.
	Analog potentiometer knob	Set the frequency; when F0.07=0, digital encoder can set the frequency as linkage control with increase/decrease key.
	Increase key	Data or function code increase (speed up the increasing rate by keeping pressing the key)
	Decrease key	Data or function code decrease (speed up the decreasing rate by keeping pressing the key)

### 3.2 LED and Indicator Light Description:

Item		Function Description	
Display Function	Digital Display	Display current run status parameter and set parameter.	
	LED Indicator	Hz,A,V	Displayed physical quantity unit (current A, voltage V, frequency Hz)
		ALM	Alarm indicator light, indicate that the VFD is in over current or over voltage suppressing status or failure alarm status currently.
		FWD	This indicator light turns green when the VFD is in forward running status.
		REV	This indicator light turns red when the VFD is in reverse running status.
		REMOTE	Remote control indicator.

Table 3-1 LED and Indicator Light Description

Item		Function Description
LED Indicator	A	Current displayed parameter is current with unit of A, LED indicator light A is on
	V	Current displayed parameter is voltage with unit of V, LED indicator light V is on
	Hz	Current displayed parameter is frequency with unit of Hz, LED indicator light Hz is on
	%	Current displayed parameter is percentage, LED indicator light Hz and V are on
	r/min	Current displayed parameter is rotational speed, LED indicator light Hz and A are on
	m/s	Current displayed parameter is linear velocity, LED indicator light V and A are on
	°C	Current displayed parameter is temperature, LED indicator light V, A and Hz are on

Table 3-2 Unit Indicator Light Description

### 3.3 Monitoring Parameter Display

Keypad display status is classified as power-on initialization display, function code and monitoring parameters display, malfunction alarm status display, run status parameters display. After power-on, LED will display "P.OFF", then enter setting frequency display status.

When the VFD is stopped, the keypad displays stopped state monitoring parameters, factory setting is digital setting frequency. As is shown in figure 3-2, unit indicator light reminds that the unit of current displayed parameter is Hz.

Press key **>>**, different monitoring parameters in stopped state can be displayed circularly (default setting in sequence is main setting frequency, bus voltage. Other monitoring parameters can be set to display by function code FE.10 ~ FE.11, for details see function code table FE.10 ~ FE.11); or without pressing **>>**, but set tens place of FE.12 as 1 (alternate display of main and secondary parameters), and the stopped state monitoring parameters will display circularly every other second automatically; also enter monitoring menu by pressing **PRG**, and check each monitoring parameter by **▲**, **▼** and **ENTER**.

### 3.4 Run Status Parameter Display

The VFD enters into run status when receiving effective run command and run status monitoring parameters normally output frequency is displayed on the keypad. As figure 1-4 shows, unit is displayed as Hz.

Press **>>** the current run status parameter will display circularly (default set is output frequency, output current, two monitoring parameters in sequence. Other parameters display can be set by FE.08 ~ FE.09, for details see parameter codes table FE.08 ~ FE.09); or without pressing **>>**, but set tens place of FE.12 as 1 (alternate display of main and secondary parameters), and the stopped state monitoring parameters will display circularly every other second automatically; also enter monitoring menu by pressing **PRG**, and check each monitoring parameter by **▲**, **▼** and **ENTER**.

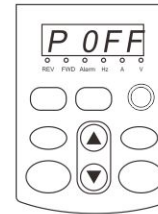

Fig 3-1 Power-on Parameter Display  
Initialization Display "P.OFF"

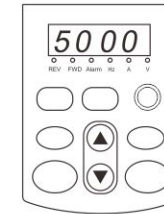

Fig 3-2 Stop Status Parameter Display  
Display Set Frequency "50.00"

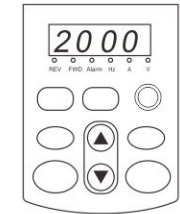

Fig 3-3 Run Status Parameter Display  
Display Current Output Frequency "20.00"

### 3.5 Malfunction Alarm Display

The VFD enters into malfunction alarm display status upon detecting failure signal and display failure code (as shown in Fig 3-4); Press **>>** to check relative parameters of stopped inverter; to check failure information, press **PRG** and enter into program mode to check D group parameter. After troubleshooting, conduct fault resetting by **STOP/RESET** key on the keypad, by control terminal or communication command. Keep displaying fault code if fault exist continuously.

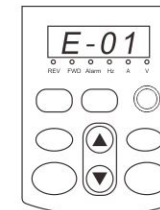

Fig 3-4 Fault Alarm Display of Over  
current during Accelerating



#### Warning:

For some serious fault, such as inverse module protect, over current, over voltage, etc., do not conduct fault reset forcibly to make the inverter run again without fault elimination confirmed, or might cause damage to the inverter.

### 3.6 Function Code Editing Display

Under stop, run or fault alarm status, press **PRG** key to enter editing status which is displayed as two classes menu (input the password first if it is preset, see password unlock instruction). Press **ENTER** key to enter items one class by one class. Under function parameter display status, press **ENTER** to conduct storage operation, press **PRG** key to return to the upper class menu without storing modified parameter.

### 3.7 Monitoring Parameter

Example 1: status parameter display switching

Under monitoring status, press **>>** key, the display will switch automatically to according value of monitoring parameter according to FD group status monitoring parameter setting, and meanwhile the corresponding unit indicator light will be on. For example, press **>>** to switch to output frequency D-00, and the indicator light of unit "Hz" is on.

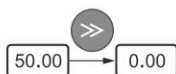

Example 2: check monitoring parameter item d-05 (output current)

Method 1:

- 1 Press **PRG** key to enter programming status, LED displays function code F0.00, press again **PRG** key, LED displays function code d-00, ficker bit stays in ones place, adjust **▲** key or **▼** key until the monitoring code turns d-05.
- 2 Press **ENTER** key, the according value of d-05 displays and the indicator light of unit "A" is on.
- 3 Press **PRG** key, escape from monitoring status.

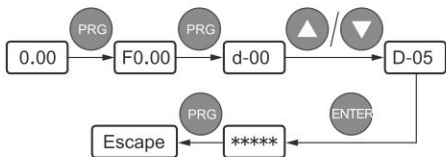

Method 2:

Under monitoring mode interface, press **ENTER** key, switch to next monitoring parameter item d-xx, press **>>** key to move ficker bit to ones digit of the monitoring code, then adjust **▲** Key or **▼** key until the monitoring code displays d-05, then operate according to step 2 and step 3 of method 1.

Example 3 : check fault monitoring parameter in fault status

- 1 Under fault status press **PRG** key and check D group monitoring parameter ranging from D-00 to D-57.
- 2 If the fault wasn't eliminated during checking the fault parameter, the interface will automatically switch to fault alarm display 5s later after stopping operation.
- 3 The fault code displays ranging from D-48 to D-57 (the current status and latest 3 times).

### 3.8 Function Code Setting

The function parameter system of this inverter includes function code F0 ~ FF, fault code E group and monitoring code D group. Each function group is consisted of several function code, which is marked as (function group code + function code).

For example, "F5.08" means eighth function code in the fifth function group.

Function code setting example:

Example 1: change frequency setting of forward jogging from 5Hz to 10Hz (F1.20 modified from 5.00Hz to 10.00Hz)

- 1 Press **PRG** key to enter programming status, LED displays function code F0.00, ficker bit stays in the ones digit.
- 2 Press **>>** key, move the ficker bit among the hundreds place, tens place and ones place.
- 3 Press **▲** key or **▼** key to modify the digit in the according digit place. LED displays F1.20.
- 4 Press **ENTER** key, it displays the according value (5.00) of F1.20, meanwhile the indicator light of unit Hz is on.
- 5 Press **>>** key, move the ficker bit to the highest place "5", press **▲** / **▼** key 5 times to change it to 10.00.
- 6 Press **ENTER** key, save the value of F1.20 and displays next function code F1.21.
- 7 Press **PRG** key, escape from programming status.

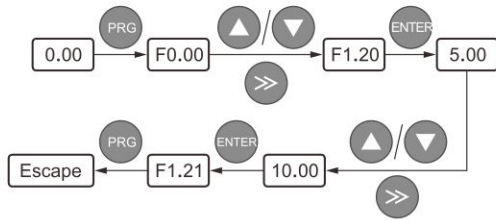

### 3.9 User Password Setting and Function Code Edit

User password setting is used for preventing unauthorized people from checking and modifying function parameter. Factory set of user password F0.00 is "00000", user can conduct parameter setting in this interface (parameter set here is only not restricted by password protection, but is restricted by conditions like whether is revisable during running, the monitoring parameters, etc.).

When setting the user password, press five-digit number and press **ENTER** to confirm, the password will take effect automatically 3 minutes later, or just power down to make it effective. After that, if the password is not set right, keypad will display "-Err-", and when checking function codes, All will display "-----" except the password item (displays "00000"). These function codes parameters can't be checked and modified until the password is set right and the keypad displays "-En--".

When password modifying is required, choose function code F0.00, and press **ENTER** to enter password authentication status. Move to modifying status after password verified successfully. Input a new password and press **ENTER** to confirm.

Power-down or wait for 3 minutes, the new password will take effect.

Example 1: change user password "22222" to "55555", check function code F1.02.

- ① Press **PRG** to enter programming status, LED displays function code F0.00, flicker bit stays in the ones place.
- ② Press **>>**, move flicker bit among hundreds place, tens place and ones place of function items.

### 3.9 User Password Setting and Function Code Edit

- ③ Press **▲** key or **▼** key to modify the digit in the according digit place. LED displays F1. 02.
- ④ Press **ENTER**, the according data "-----" of F1. 02 is displayed.
- ⑤ Press **ENTER** to enter F1.03, repeat step 2 and step 3, check according data "00000" of F0.00.
- ⑥ Press **▲** key or **▼** key to modify the digit in the according digit place, LED displays "22222", and the password is set up.
- ⑦ Press **ENTER**, it displays "-En--", meanwhile function code displays F0.01.
- ⑧ Repeat step 2 and step 3, check the according data "00000" of F0.00 and modify it to "55555", press **ENTER** to end the password changing, enter F0.01 item.
- ⑨ Repeat step 2 and step 3, check the according data "0.0" of F1.02, conduct modifying by **▲** key or **▼** key.
- ⑩ Press **PRG**, escape from edit status.

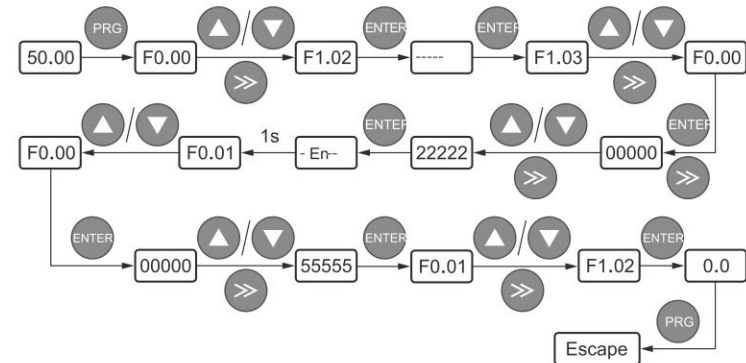

## 4 Function Parameter Table and Description

### 4.0 Monitoring Parameter Group and Fault Record

○—modifiable parameter under any condition   ×—not modifiable parameter under run status  
 ◆—the actual detected parameter, not modifiable   ◇—factory parameter, only modifiable for factory, not allowed for users modifying

D Group - Monitoring Parameter Group and Fault Record

Function Code	Name	Set Range	Minimum Unit	Factory Default	Modification
d-00	Output Frequency	0.00 ~ maximum output frequency 【F0.15】	0.01Hz	0.00	◆
d-01	Set Frequency	0.00 ~ maximum output frequency 【F0.15】	0.01Hz	0.00	◆
d-02	Estimated Motor Frequency	0.00 ~ maximum output frequency 【F0.15】 Note: motor running frequency converted from estimated motor speed	0.01Hz	0.00	◆
d-03	Main Set Frequency	0.00 ~ maximum output frequency 【F0.15】	0.01Hz	0.00	◆
d-04	Auxiliary Set Frequency	0.00 ~ maximum output frequency 【F0.15】	0.01Hz	0.00	◆
d-05	Output Current	0.0 ~ 6553.5A	0.1A	0.0	◆
d-06	Output Voltage	0 ~ 999V	1V	0	◆
d-07	Output Torque	-200.0 ~ +200.0%	0.1%	0.0%	◆
d-08	Motor Revolving Speed (RPM/min)	0 ~ 36000 (RPM/min)	1	0	◆
d-09	Motor Power Factor	0.00 ~ 1.00	0.01	0.00	◆
d-10	Run Linear Velocity (m/s)	0.01 ~ 655.35(m/s)	0.01 m/s	0.00	◆
d-11	Set Linear Velocity (m/s)	0.01 ~ 655.35(m/s)	0.01 m/s	0.00	◆
d-12	Bus voltage (V)	0 ~ 999V	1V	0	◆
d-13	Input Voltage (V)	0 ~ 999V	1V	0	◆
d-14	PID Set Value (V)	0.00 ~ 10.00V	0.01V	0.00	◆

### 4.0 Monitoring Parameter Group and Fault Record

D Group - Monitoring Parameter Group and Fault Record

Function Code	Name	Set Range	Minimum Unit	Factory Default	Modification
d-15	PID Feedback (V)	0.00 ~ 10.00V	0.01V	0.00	◆
d-16	Analog Input AI1(V/mA)	0.00 ~ 10.00V/20mA	0.01V	0.00	◆
d-17	Analog Input AI2(V)	0.00 ~ 10.00V	0.01V	0.00	◆
d-18	Impulse Frequency Input (KHz)	0.00 ~ 50.00KHz	0.01KHz	0.00	◆
d-19	Analog Output AO1(V/mA)	0.00 ~ 10.00V/20mA	0.01V	0.00	◆
d-20	Analog Output AO2(V)	0.00 ~ 10.00V	0.01V	0.00	◆
d-21	Input Terminal Status	0 ~ FFH Note: the sequence from high to low order digit in binary system X8/X7/X6/X5/X4/X3/X2/X1	1	0	◆
d-22	Output Terminal Status	0~FH Note: the sequence from high to low order digit in binary system R2/R1/Y2/Y1	1	0	◆
d-23	VFD Running Status	0 ~ FFFFH BIT0: run/stop BIT1: reverse/forward BIT2: zero-speed running BIT3: reserved BIT4: accelerating BIT5: decelerating BIT6: constant speed running BIT7: pre-excitation BIT8: tuning of VFD parameter BIT9: overcurrent limit BIT10: overvoltage limit BIT11: amplitude limiting of torque BIT12: amplitude limiting of speed BIT13: speed control BIT14: torque control BIT15: reserved	1	0	◆

#### 4.0 Monitoring Parameter Group and Fault Record

D Group - Monitoring Parameter Group and Fault Record					
Function Code	Name	Set Range	Minimum Unit	Factory Default	Modification
d-24	Current stage of multistage speed	0~15	1	0	◆
d-25	reserved	—	—	0	◆
d-26	reserved	—	—	0	◆
d-27	Current count value	0 ~ 65535	1	0	◆
d-28	Set count value	0 ~ 65535	1	0	◆
d-29	Current timing value(S)	0 ~ 65535s	1S	0	◆
d-30	Set timing value(S)	0 ~ 65535s	1S	0	◆
d-31	Current length	0.000 ~ 65.535(KM)	0.001KM	0.000	◆
d-32	Set length	0.000 ~ 65.535(KM)	0.001KM	0.000	◆
d-33	Radiator Temperature 1	0.0°C ~ +1 10.0°C	0.1°C	0.0	◆
d-34	Radiator Temperature 2	0.0°C ~ +1 10.0°C	0.1°C	0.0	◆
d-35	accumulative run time of VFD (hour)	0 ~ 65535H	1H	0	◆
d-36	accumulative power-on time of VFD (hour)	0 ~ 65535H	1H	0	◆
d-37	accumulative run time of fan (hour)	0 ~ 65535H	1H	0	◆
d-38	Accumulative electricity consumption (low order digit)	0 ~ 9999KWH	1KWH	0	◆
d-39	Accumulative electricity consumption (high order digit)	0 ~ 9999KWH (* 10000)	1KWH	0	◆
d-40	Special model monitoring parameter (reserved)	—	—	0	◆
d-41	Special model monitoring parameter (reserved)	—	—	0	◆
d-42	Special model monitoring parameter (reserved)	—	—	0	◆
d-43	Special model monitoring parameter (reserved)	—	—	0	◆

#### 4.0 Monitoring Parameter Group and Fault Record

D Group - Monitoring Parameter Group and Fault Record					
Function Code	Name	Set Range	Minimum Unit	Factory Default	Modification
d-44	Special model monitoring parameter (reserved)	—	—	0	◆
d-45	Special model monitoring parameter (reserved)	—	—	0	◆
d-46	Special model monitoring parameter (reserved)	—	—	0	◆
d-47	Special model monitoring parameter (reserved)	—	—	0	◆
d-48	The third to last fault type	0~30	1	0	◆
d-49	The second to last fault type	0~30	1	0	◆
d-50	Last fault type	0~30	1	0	◆
d-51	Current fault type	0~30	1	0	◆
d-52	Run frequency of current fault	0.00 ~ 【F0.16】 upper limit of frequency	0.01Hz	0.00	◆
d-53	Output current of current fault	0.0 ~ 6553.5A	0.1A	0.0	◆
d-54	Busbar voltage of current fault	0 ~ 999V	1V	0	◆
d-55	Input terminal status of current fault	0 ~ FFH Note: sequence from high to low order digit in binary system X8/X7/X6/X5/X4/X3/X2/X1	1	0	◆
d-56	Output terminal status of current fault	0 ~ FH Note: sequence from high to low order digit in binary system R1/Y2/Y1	1	0	◆
d-57	Run state of current fault	0 ~ FFFFH	1	0	◆



## 4.1 Function Code

○—modifiable parameter under any condition    ×—not modifiable parameter under run status  
 ◆—the actual detected parameter, not modifiable    ◇—factory parameter, only modifiable for factory, not allowed for users modifying

F0 Group - Basic Run Parameters

Function Code	Name	Set Range	Minimum Unit	Factory Default	Modification
F0.00	/	/	/	/	×
F0.01	Control software version	1.00 ~ 99.99	0.01	1.02	◆
F0.02	Operation panel software version	1.00 ~ 99.99	0.01	1.00	◆
F0.03	VFD rated power	0.4 ~ 999.9KW (G/P)	0.1KW	Depending on model	◆
F0.04	VFD type	0: G type ( constant torque load type) 1: P type (fan, water pump load type) Note 1: set as P type, and the VFD parameters will refresh automatically, without modifying any parameter the VFD can be used as inverter of higher grade for application of fan and water pump. Note 2: can not be initialized, please modify it manually.	1	0	×

## 4.1 Function Code

F0 Group - Basic Run Parameters

Function Code	Name	Set Range	Minimum Unit	Factory Default	Modification
F0.05	Control mode	0: common V/F control (manually torque boost) 1: advanced V/F control (automatically torque boost) 2: open loop current vector control (SVC) 3: closed loop current vector control (rserved) 4: separatd type V/F control Note 1: choose control method 3 (closed loop current vector control), input terminal X6 can only be used for ordinary terminal, not for high-speed pulse input. Note 2: this parameter can not be initialized, please modify it manually.	1	Depending on model	×
F0.06	operation command channel	0: operation panel run command channel 1: terminal run command channel 2: communication run command channel	1	0	○
F0.07	Main frequency source A	0: digital set 1 (keypad ▲ / ▼ key, encoder+F0.12) 1: digital set 2 (terminal UP/DOWN adjust +F0.13) 2: digital set 3 (communication set) 3: AI1 analog set (0 ~ 10V/20mA) 4: AI2 analog set (0 ~ 10V) 5: pulse set (0 ~ 50KHZ) 6: easy PLC set 7: multistage speed run set 8: PID control set 9: panel Potentiometer 10: MPPT turn on	1	0	○

### 4.1 Function Code

F0 Group - Basic Run Parameters					
Function Code	Name	Set Range	Minimum Unit	Factory Default	Modification
F0.08	Auxiliary frequency source B	0: digital set 1 (keypad ▲ / ▼ key, encoder+F0.12) 1: digital set 2 (terminal UP/DOWN adjust +F0.13) 2: digital set 3 (communication set) 3: AI1 analog set (0 ~ 10V/20mA) 4: AI2 analog set (0 ~ 10V) 5: pulse set (0 ~ 50KHZ) 6: easy PLC set 7: multistage speed run set 8: PID control set 9: panel potentiometer	1	3	○
F0.09	Frequency source	0: main frequency source A 1: A+K*B 2: A-K*B 3:   A-K*B   4: MAX (A, K*B) 5: MIN (A, K*B) 6: switch from A to K*B (A prior to K*B) 7: switch from A to (A+K*B) (A prior to A+K*B) 8: switch from A to (A-K*B) (A prior to A-K*B) Note 1: frequency switch needs Note 2: compared with frequency source set method, traverse operation has a higher priority.	1	0	○

### 4.1 Function Code

F0 Group - Basic Run Parameters					
Function Code	Name	Set Range	Minimum Unit	Factory Default	Modification
F0.10	Digital set 1 control	LED ones digit: power down storage 0: storage 1: not storage LED tens digit: hold when stop 0: hold 1: not hold	1	000	○
F0.11	Digital set 2 control	LED hundred digit: ▲ / ▼ key, UP/DOWN frequency 0: invalid 1: valid LED thousands digit: reserved	1	000	○
F0.12	Frequency source digital setting 1	0.00Hz ~ 【F0.16】 upper limit of frequency	0.01Hz	50.00	○
F0.13	Frequency source digital setting 2	0.00Hz ~ 【F0.16】 upper limit of frequency	0.01Hz	50.00	○
F0.14	Auxiliary frequency source weight coefcient K setting	0.01 ~ 10.00	0.01	1.00	○
F0.15	Maximum output frequency	Low frequency range: MAX {50.00, 【F0.16】 } ~ 300.00 High frequency range: MAX {50.00, 【F0.16】 } ~ 3000.0	0.01Hz	50.00	×
F0.16	Upper limit frequency	【F0.17】 ~ 【F0.15】	0.01Hz	50.00	×
F0.17	Lower limit frequency	0.00Hz ~ 【F0.16】	0.01Hz	0.00	×

#### 4.1 Function Code

F0 Group - Basic Run Parameters					
Function Code	Name	Set Range	Minimum Unit	Factory Default	Modification
F0.18	Frequency output mode	0: low frequency mode (0.00 ~ 300.00Hz) 1: high frequency mode (0.0 ~ 3000.0Hz) Note: high frequency mode is only effective to VF control	1	0	×
F0.19	Acceleration time 1	0.1 ~ 3600.0s 0.4 ~ 4.0KW 7.5s	0.1s	Depending on model	○
F0.20	Deceleration time 1	5.5 ~ 30.0KW 15.0s 37.0 ~ 132.0KW 30.0s 160.0 ~ 630.0KW 60.0s	0.1s	Depending on model	○
F0.21	Running direction	0: forward 1: reverse 2: prevent reversing	1	0	×
F0.22	Carrier frequency	1.0 ~ 16.0KHz 0.4 ~ 4.0KW 6.0KHz 1.0 ~ 16.0KHz 5.5 ~ 30KW 4.0KHz 1.0 ~ 16.0KHz 37 ~ 132KW 2.5KHz 1.0 ~ 10.0KHz 160 ~ 630KW 1.5KHz 1.0 ~ 5.0KHz	0.1KHz	Depending on model	○
F0.23	User password	1: 0 ~ 9: no password protection 2: The password setting is successful and will take 3 minutes to take effect 3: Write protection is not valid for this parameter and cannot be initialized	1	0	○

#### 4.1 Function Code

F1 Group - Auxiliary Operating Parameters					
Function Code	Name	Set Range	Minimum Unit	Factory Default	Modification
F1.00	Start mode	0: start at start frequency 1: DC braking + start at start frequency 2: start with speed tracking	1	0	×
F1.01	Start frequency	0.00 ~ 50.00Hz	0.01Hz	1.00	○
F1.02	Start frequency hold time	0.0 ~ 100.0s	0.1s	0.0	○
F1.03	DC brake current at startup	0.0 ~ 150.0% *rated current of motor	0.1%	0.0%	○
F1.04	DC brake time at startup	0.0 ~ 100.0s	0.1s	0.0	○
F1.05	Accelerating and decelerating mode	0: linear Acc/Dec mode 1: S curve Acc/Dec mode	1	0	×
F1.06	Time ratio of initial segment in S curve	10.0 ~ 50.0%	0.1%	20.0%	○
F1.07	Time ratio of ending segment in S curve	10.0 ~ 50.0%	0.1%	20.0%	○
F1.08	Stop mode	0: Decelerate to stop 1: coast to stop	1	0	×
F1.09	Frequency threshold of DC brake	0.00 ~ 【F0.16】 upper limit frequency	0.01Hz	0.00	○
F1.10	DC brake delay time	0.0 ~ 100.0s	0.1s	0.0	○
F1.11	DC brake current	0.0 ~ 150.0% *rated current of motor	0.1%	0.0%	○
F1.12	DC brake time at stop	0.0 ~ 100.0s	0.1s	0.0	○
F1.13	Acc time 2	0.1 ~ 3600.0s 0.4 ~ 4.0KW 7.5s 5.5 ~ 30.0KW 15.0s 37.0 ~ 132.0KW 40.0s 160.0 ~ 630.0KW 60.0s	0.1	Depending on model	○
F1.14	Dec time 2		0.1	Depending on model	○
F1.15	Acc time 3		0.1	Depending on model	○
F1.16	Dec time 3		0.1	Depending on model	○
F1.17	Acc time 4		0.1	Depending on model	○
F1.18	Dec time 4		0.1	Depending on model	○

## 4.1 Function Code

F1 Group - Auxiliary Operating Parameters					
Function Code	Name	Set Range	Minimum Unit	Factory Default	Modification
F1.19	Acc/Dec time unit	0: second 1: minute 2: 0.1s	1	0	○
F1.20	Frequency setting of forward jog operation	0.00 ~ 【F0.16】 upper limit frequency	0.01Hz	5.00	○
F1.21	Frequency setting of reverse jog operation	0.00 ~ 【F0.16】 upper limit frequency	0.01Hz	5.00	○
F1.22	Jog Acc time	0.1 ~ 3600.0s 0.4 ~ 4.0KW 7.5s 5.5 ~ 30.0KW 15.0s	0.1s	Depending on model	○
F1.23	Jog Dec time	37.0 ~ 132.0KW 40.0s 160.0 ~ 630.0KW 60.0s	0.1s	Depending on model	○
F1.24	Jog interval time	0.0 ~ 100.0s	0.1s	0.1	○
F1.25	Hopping freq.1	0.00 ~ upper limit freq.	0.01Hz	0.00	○
F1.26	Hopping freq.1 range	0.00 ~ upper limit freq.	0.01Hz	0.00	○
F1.27	Hopping freq.2	0.00 ~ upper limit freq.	0.01Hz	0.00	○
F1.28	Hopping freq.2 range	0.00 ~ upper limit freq.	0.01Hz	0.00	○
F1.29	Hopping freq.3	0.00 ~ upper limit freq.	0.01Hz	0.00	○
F1.30	Hopping freq.3 range	0.00 ~ upper limit freq.	0.01Hz	0.00	○
F1.31	Action when set freq. is lower than lower limit freq.	0: run at lower limit freq. 1: run at zero freq. after delay time (start without delay) 2: stop after delay time (start without delay)	1	0	×
F1.32	Delay time of stopping when freq. is lower than limit (simple sleep)	0.0 ~ 3600.0s	0.1s	10.0	○
F1.33	Zero freq. brake current	0.0 ~ 150.0%*rated current of motor	0.1	0.0	×
F1.34	FWD/REV transition time	0.0 ~ 100.0s	0.1s	0.0	○
F1.35	FWD/REV switch mode	0: over zero freq. switch 1: over start freq. switch	1	0	×
F1.36	Standby deceleration time when emergency brake	0.1 ~ 3600.0s	0.1s	1.0	○

## 4.1 Function Code

F2 Group - Motor Parameters					
Function Code	Name	Set Range	Minimum Unit	Factory Default	Modification
F2.00	Motor type	0: AC asynchronous motor 1: PMSM ( reserved ) Note 1: only closed-loop vector control is acceptable by synchronous machine at present Note 2: this parameter can not be initialized, please modify it manually.	1	0	×
F2.01	Motor's rated power	0.4 ~ 999.9KW	0.1KW	Depending on model	×
F2.02	Motor's rated freq.	0.01Hz ~ 【F0.15】 maximum freq.	0.01Hz	50.00	×
F2.03	Motor's rated speed	0 ~ 60000RPM	1RPM	Depending on model	×
F2.04	Motor's rated voltage	0 ~ 999V	1V	Depending on model	×
F2.05	Motor's rated current	0.1 ~ 6553.5A	0.1A	Depending on model	×
F2.06	Stator resistance of asynchronous motor	0.001 ~ 20.000Ω	0.001Ω	Depending on model	×
F2.07	Rotor resistance of asynchronous motor	0.001 ~ 20.000Ω	0.001Ω	Depending on model	×
F2.08	Stator and rotor inductance of asynchronous motor	0.1 ~ 6553.5mH	0.1mH	Depending on model	×
F2.09	Stator and rotor mutual inductance of asynchronous motor	0.1 ~ 6553.5mH	0.1mH	Depending on model	×



## 4.1 Function Code

F2 Group - Motor Parameters					
Function Code	Name	Set Range	Minimum Unit	Factory Default	Modification
F2.10	No-load current of asynchronous motor	0.01 ~ 655.35A	0.01A	Depending on model	×
F2.11- F2.15	Reserved	—	—	0	◆
F2.16	Motor tuning	0: no action 1: static tuning 2: no-load complete tuning 3: on-load complete tuning	1	0	×
F2.17	pre-excitation time of asynchronous motor	0.00 ~ 10.00s 0.4 ~ 4.0KW 0.05s 5.5 ~ 30KW 0.1s 37 ~ 132KW 0.30s 160 ~ 630KW 0.50s note: invalid for VF control	0.01s	Depending on model	×
F3 Group - Reserved Parameters					
F4 Group - Speed Loop, Torque and Flux Control Parameters					
F4.00	Speed loop (ASR1) proportional gain	0.000 ~ 6.000	0.001	1.000	○
F4.01	Speed loop (ASR1) integral time	0.000 ~ 32.000s	0.001s	1.000	○
F4.02	ASR1 filter time constant	0.000 ~ 0.100s	0.001s	0.000	○
F4.03	Switch low point freq.	0.00Hz ~ 【F4.07】	0.01Hz	5.00	○

## 4.1 Function Code

F4 Group - Speed Loop, Torque and Flux Control Parameters					
Function Code	Name	Set Range	Minimum Unit	Factory Default	Modification
F4.04	Speed loop (ASR2) proportional gain	0.000 ~ 6.000	0.001	1.500	○
F4.05	Speed loop (ASR2) Integral time	0.000 ~ 32.000s	0.001s	0.500	○
F4.06	ASR2 filter time constant	0.000 ~ 0.100s	0.001s	0.000	○
F4.07	Switch high point freq.	【F4.03】 ~ 【F0.16】 upper limit freq.	0.01Hz	10.00	○
F4.08	Vector control of positive slip compensation factor (electromotion state)	50.0% ~ 200.0%*rated slip frequency	0.1%	100.0%	○
F4.09	Vector control of negative slip compensation factor (braking state)	50.0% ~ 200.0%*rated slip frequency	0.1%	100.0%	○
F4.10	Speed and torque control	0: speed 1: torque 2: valid conditionally (terminal switch)	1	0	×
F4.11	Speed and torque switching delay	0.01 ~ 1.00s	0.01s	0.05	×
F4.12	Torque command	0: keypad set 1: AI1 2: AI2 3: communication set	1	0	○

#### 4.1 Function Code

F4 Group - Speed Loop, Torque and Flux Control Parameters					
Function Code	Name	Set Range	Minimum Unit	Factory Default	Modification
F4.13	Torque set by keypad	-200.0% ~ 200.0%*rated current of motor	0.1%	0.0%	○
F4.14	Speed limit channel 1 of torque control mode (forward)	0: keypad set 1 1: AI1 2: AI2	1	0	○
F4.15	speed limit channel 1 of torque control mode (reverse)	0: keypad set 2 1: AI1 2: AI2	1	0	○
F4.16	Keypad limit speed 1	0.0 ~ 100.0%* 【F0.15】 maximum freq.	0.1%	100.0%	○
F4.17	Keypad limit speed 2	0.0 ~ 100.0%* 【F0.15】 maximum freq.	0.1%	100.0%	○
F4.18	Torque rise time	0.0 ~ 10.0s	0.1s	0.1	○
F4.19	Torque decline time	0.0 ~ 10.0s	0.1s	0.1	○
F4.20	Electromotion torque limit of vector mode	G type: 0.0%~ 200.0% *rated current of motor 180.0% P type: 0.0%~ 200.0% *rated current of motor 120.0%	0.1%	Depending on model	○
F4.21	braking torque limit of vector mode	G type: 0.0%~ 200.0% *rated current of motor 180.0% P type: 0.0%~ 200.0% *rated current of motor 120.0%	0.1%	Depending on model	○

#### 4.1 Function Code

F4 Group - Speed Loop, Torque and Flux Control Parameters					
Function Code	Name	Set Range	Minimum Unit	Factory Default	Modification
F4.22	Torque detection action	0: detect invalid 1: keep running after over torque detected during constant speed 2: keep running after over torque detected during running 3: cut of output after over torque detected during constant speed 4: cut of output after over torque detected during running 5: keep running after torque shortage detected during constant speed 6: keep running after torque shortage detected during running 7: cut of output after torque shortage detected during constant speed 8: cut of output after torque shortage detected during running	1	0	×
F4.23	Torque detection level	G type: 0.0% ~ 200.0 % *rated current of motor 150.0% P type: 0.0% ~ 200.0 %*rated current of motor 110.0%	0.1%	Depending on model	×
F4.24	Torque detection time	0.0 ~ 10.0s	0.1s	0.0	×
F4.25	Cut of freq.of static friction coefcient	0.00 ~ 300.00Hz	0.01Hz	10.00	○
F4.26	Static friction coefcient set	0.0 ~ 200.0	0.1	0.0	○
F4.27	Hold time of static friction coefcient	0.00 ~ 600.00s	0.01S	0.00	×

## 4.1 Function Code

F5 Group - VF Control Parameters					
Function Code	Name	Set Range	Minimum Unit	Factory Default	Modification
F5.00	V/F curve set	0: linear curve 1: decreasing torque curve 1( 1.3 power) 2: decreasing torque curve 2(1.5 power) 3: decreasing torque curve 3(1.7 power) 4: square curve 5: user set V/F curve (determined by F5.01 ~ F5.06)	1	0	×
F5.01	V/F frequency F1	0.00 ~ F2 (frequency value)	0.01Hz	12.50	×
F5.02	V/F voltage V1	0.0 ~ V2 (voltage value)	0.1%	25.0%	×
F5.03	V/F frequency F2F	1 ~ F3 (frequency value)	0.01Hz	25.00	×
F5.04	V/F voltage V2	V1 -V3 (voltage value)	0.1%	50.0%	×
F5.05	V/F frequency F3	Freq. Value F2 ~ 【F2.02】 rated freq. of motor	0.01Hz	37.50	×
F5.06	V/F voltage V3	Voltage value V2 ~ 100.0%* 【F2.04】 rated voltage of motor	0.1%	75.0%	×
F5.07	Torque boost setting	0.0 ~ 30.0%*rated voltage of motor 【F2.04】	0.1%	Depending on model	×
F5.08	Torque boost cutoff point	0.00 ~ rated freq. of motor	0.01Hz	50.00	×
F5.09	V/F control slip frequency compensation	0.0 ~ 200.0% *rated slip note: default as 100.0% in advanced VF control mode	0.1%	0.0%	○
F5.10	V/F control slip compensation filtering coefficients	1~10	1	3	○
F5.11	V/F control torque compensation filtering coefficients	0~10	1	0	○

## 4.1 Function Code

F5 Group - VF Control Parameters					
Function Code	Name	Set Range	Minimum Unit	Factory Default	Modification
F5.12	Separated type V/F control	0: VF half separated mode, voltage open-loop output 1: VF half separated mode, voltage closed-loop output 2: VF complete separated mode, voltage open-loop output 3: VF complete separated mode, voltage closed-loop output Note 1: when choose VF separated control, please close the dead-time compensation function Note 2: half separated concept is based on that during start-up the frequency and voltage of VFD remains the VVVF relation, but get separated after the reaching of set frequency	1	0	×
F5.13	Voltage setting channel	0: digital setting 1: AI1 2: AI2	1	0	○
F5.14	voltage feedback method of voltage close-loop output	0: AI1 1: AI2 note: only valid for closed loop output mode	1	0	×
F5.15	Output voltage of digital setting	0.0 ~ 200.0% *rated voltage of motor note: in open loop output mode, the maximum output voltage is 100.0% of rated voltage of motor	0.1%	100.0%	○
F5.16	Deviation limit of voltage closed loop regulation	0.0 ~ 5.0% *rated voltage of motor	0.1%	2.0%	×

## 4.1 Function Code

F5 Group - VF Control Parameters					
Function Code	Name	Set Range	Minimum Unit	Factory Default	Modification
F5.17	VF curve max. voltage of half separation mode	0.0 ~ 100.0%*rated voltage of motor note: this voltage represents output voltage of VFD	0.1%	80.0%	×
F5.18	controller adjustment cycle of voltage closed loop output	0.01 ~ 10.00s	0.01s	0.10	×
F5.19	Voltage rising time	0.1 ~ 3600.0s note: this parameter is only valid for open loop output mode of complete separated voltage	0.1s	10.0	○
F5.20	Voltage declining time		0.1s	10.0	○
F5.21	Voltage feedback disconnection treatment	0: alarm and keep running with the voltage of disconnection moment 1: alarm and keep running with decreased voltage of amplitude limiting value 2: protection action and free stop	1	0	×
F5.22	Detection value of voltage feedback disconnection	0.0 ~ 100.0%*rated voltage of motor	0.1%	2.0%	○
F5.23	Detection time of voltage feedback disconnection	0.0 ~ 100.0s	0.1s	10.0	○
F5.24	Limit voltage of voltage feedback disconnection	0.0 ~ 100.0%*rated voltage of motor note: this voltage represents the output voltage of VFD, and reasonable setting of this parameter could prevent machine damage resulting from voltage overshoot at disconnection moment.	0.1%	80.0%	○

## 4.1 Function Code

F6 Group - Analog Quantity and Pulse Input and Output Parameters					
Function Code	Name	Set Range	Minimum Unit	Factory Default	Modification
F6.00	AI1 input corresponding physical quantity	0: speed command (output freq., -100.0% ~ 100.0%) 1: torque command (output torque, -200.0% ~ 200.0%) 2: voltage command (output voltage, 0.0% ~ 200.0% *rated voltage of motor)	1	0	×
F6.01	AI1 input lower-limit	0.00V/0.00mA ~ 10.00V/20.00mA	0.01V	0.00	○
F6.02	AI1 lower limit corresponding physical quantity set	-200.0% ~ 200.0% note: range is relevant to P6.00	0.1%	0.0%	○
F6.03	AI1 input upper limit	0.00V/0.00mA ~ 10.00V/20.00mA	0.01V	10.00	○
F6.04	AI1 upper limit corresponding physical quantity setting	-200.0% ~ 200.0% note: range is relevant to P6.00	0.1%	100.0%	○
F6.05	AI1 input smoothing time	0.00s ~ 10.00s	0.01s	0.05	○
F6.06	AI2 input corresponding physical quantity	0: speed command (output freq., -100.0% ~ 100.0%) 1: torque command (output torque, -200.0% ~ 200.0%) 2: voltage command (output voltage, 0.0% ~ 200.0% *rated voltage of motor)	1	0	×
F6.07	AI2 input lower limit	0.00V ~ 10.00V	0.01V	0.00	○
F6.08	AI2 lower limit corresponding physical quantity setting	-200.0% ~ 200.0% note: range is relevant to P6.00	0.1%	0.0%	○



## 4.1 Function Code

F6 Group - Analog Quantity and Pulse Input and Output Parameters					
Function Code	Name	Set Range	Minimum Unit	Factory Default	Modification
F6.09	AI2 input upper limit	0.00V ~ 10.00V	0.01V	10.00	○
F6.10	AI2 upper limit corresponding physical quantity setting	-200.0% ~ 200.0% note: range is relevant to P6.00	0.1%	100.0%	○
F6.11	AI2 input filtering time	0.00s ~ 10.00s	0.01s	0.05	○
F6.12	Error limit of analog input	0.00V ~ 10.00V	0.01V	0.00	○
F6.13	Threshold of zero freq. operation	Zero freq. hysteresis ~ 50.00Hz	0.01Hz	0.00	○
F6.14	zero freq. hysteresis	0.00 ~ zero freq. threshold value	0.01Hz	0.00	○
F6.15	External impulse input corresponding physical quantity	0: speed command (output freq., -100.0% ~ 100.0%) 1: torque command (output torque, 200.0% ~ 200.0%)	1	0	×
F6.16	External impulse input lower limit	0.00 ~ 50.00KHz	0.01KHz	0.00	○
F6.17	External impulse input corresponding physical quantity	-200.0% ~ 200.0% note: range is relevant to P6.15	0.1%	0.0%	○
F6.18	External impulse input lower limit	0.00 ~ 50.00KHz	0.01KHz	50.00	○
F6.19	external impulse lower limit corresponding physical quantity set	-200.0% ~ 200.0% note: range is relevant to P6.15	0.1%	100.0%	○
F6.20	external impulse input filtering time	0.00 ~ 10.00s	0.01s	0.05	○

## 4.1 Function Code

F6 Group - Analog Quantity and Pulse Input and Output Parameters					
Function Code	Name	Set Range	Minimum Unit	Factory Default	Modification
F6.21	AO1 multi-function analog output terminal	0: output frequency ( before slip compensation) 1: output frequency (after slip compensation) 2: set frequency 3: motor speed (estimated value)	1	0	○
F6.22	AO2 multi-function analog output terminal	4: output current 5: output voltage 6: but voltage 7: PID specified value 8: PID feedback value	1	4	○
F6.23	DO multi-function impulse output terminal	9: AI1 10: AI2 11: input pulse freq. 12: torque current 13: fux current	1	11	○
F6.24	Physical quantity correspond to AO1 output lower limit	-200.0% ~ 200.0%	0.1%	0.0%	○
F6.25	AO1 output lower limit	0.00 ~ 10.00V	0.01V	0.00	○
F6.26	Physical quantity correspond to AO1 output upper limit	-200.0% ~ 200.0%	0.1%	100.0%	○
F6.27	AO1 output upper limit	0.00 ~ 10.00V	0.01V	10.00	○
F6.28	Physical quantity correspond to AO2 output lower limit	-200.0% ~ 200.0%	0.1%	0.0%	○
F6.29	AO2 output lower limit	0.00 ~ 10.00V	0.01V	0.00	○
F6.30	Physical quantity correspond to AO2 output upper limit	-200.0% ~ 200.0%	0.1%	100.0%	○
F6.31	AO2 output upper limit	0.00 ~ 10.00V	0.01V	10.00	○

#### 4.1 Function Code

F6 Group - Analog Quantity and Pulse Input and Output Parameters					
Function Code	Name	Set Range	Minimum Unit	Factory Default	Modification
F6.32	Physical quantity correspond to DO output lower limit	-200.0% ~ 200.0%	0.1%	0.0%	○
F6.33	DO output lower limit	0.00 ~ 50.00KHz	0.01KHz	0.00	○
F6.34	Physical quantity correspond to DO output upper limit	-200.0% ~ 200.0%	0.1%	100.0%	○
F6.35	DO output upper limit	0.00 ~ 50.00KHz	0.01KHz	50.00	○
F6.36	AI multipoint curve selection	the unit of LED: AI1 multipoint curve selection 0: forbidden 1: efective the tens of LED: AI2 multipoint curve selection 0: forbidden 1: efective the hundreds of LED: analog input signal selection 0: AI1 and AI2 input signal 0 ~ 10V 1: AI1 input signal 4 ~ 20mA, AI2 input signal 0 ~ 10V 2: AI2 input signal 4 ~ 20mA, AI1 input signal 0 ~ 10V 3: AI1 and AI2 input signal 4 ~ 20mA the thousands of LED: reserved	1	00	×
F6.37	AI1 curve min input	0.00 ~ 【F6.39】	0.01V	0.00	○
F6.38	AI1 curve min input Corresponding setting	-200.0% ~ 200.0% Note: range associated with F6.00	0.1%	0.0%	○

#### 4.1 Function Code

F6 Group - Analog Quantity and Pulse Input and Output Parameters					
Function Code	Name	Set Range	Minimum Unit	Factory Default	Modification
F6.39	AI1 curve infexion point 1 input	【F6.37】 ~ 【F6.41】	0.01V	3.00	○
F6.40	AI1 curve infexion point 1 input Corresponding setting	-200.0% ~ 200.0% Note: range associated with F6.00	0.1%	30.0%	○
F6.41	AI1 curve infexion point 2 input	【F6.39】 ~ 【F6.43】	0.01V	6.00	○
F6.42	AI1 curve infexion point 2 input Corresponding setting	-200.0% ~ 200.0% Note: range associated with F6.00	0.1%	60.0%	○
F6.43	AI1 curve max input	【F6.41】 ~ 10.00	0.01V	10.00	○
F6.44	AI1 curve max input Corresponding setting	-200.0% ~ 200.0% Note: range associated with F6.00	0.1%	100.0%	○
F6.45	AI2 curve min input	0.00 ~ 【F6.47】	0.01V	0.00	○
F6.46	AI2 curve min input Corresponding setting	-200.0% ~ 200.0% Note: range associated with F6.00	0.1%	0.0%	○
F6.47	AI2 curve infexion point 1 input	【F6.45】 ~ 【F6.49】	0.01V	3.00	○
F6.48	AI2 curve infexion point 1 input Corresponding setting	-200.0% ~ 200.0% Note: range associated with F6.00	0.1%	30.0%	○
F6.49	AI2 curve infexion point 2 input	【F6.47】 ~ 【F6.51】	0.01V	6.00	○
F6.50	AI2 curve infexion point 2 input Corresponding setting	-200.0% ~ 200.0% Note: range associated with F6.00	0.1%	60.0%	○
F6.51	AI2 curve max input	【F6.49】 ~ 10.00	0.01V	10.00	○
F6.52	AI2 curve max input Corresponding setting	-200.0% ~ 200.0% Note: range associated with F6.00	0.1%	100.0%	○
F6.53	AI1 input voltage protection upper limit	【6.54】 ~ 10.00V	0.01V	6.80	○
F6.54	AI1 input voltage protection lower limit	0.00V ~ 【6.53】	0.01V	3.10	○

## 4.1 Function Code

F7 Group - Digital Input and Output Parameters					
Function Code	Name	Set Range	Minimum Unit	Factory Default	Modification
F7.00	Input X1 function (when F8.21 is non-zero, default as function NO.58)	0: control terminal idle 1: forward run (FWD) 2: reverse run (REV) 3: three-wire running control 4: forward jog control 5: reverse jog control 6: free shutdown control 7: external reset signal input(RST) 8: external fault normally-open input 9: external fault normally-close input 10: emergency stop function (brake with)	1	1	×
F7.01	Input X2 function (when F8.21 is non-zero, default as function NO.59)	11: reserved 12: freq.increase 13: freq.decrease 14: UP/DOWN terminal freq. zero clearing	1	2	×
F7.02	Input X3 function (when F8.21 is non-zero, default as function NO.60)	15: multi-speed 1 16: multi-speed 2 17: multi-speed 3 18: multi-speed 4 19: ACC/DEC time TT1 20: ACC/DEC time TT2 21: run command channel 1 22: run command channel 2 23: VFD ACC/DEC prohibit 24: VFD operation prohibiting	1	4	×
F7.03	Input X4 function (when F8.21 is non-zero, default as function NO.61)	25: run command switch to keypad 26: run command switch to terminal 27: run command switch to communication 28: auxiliary freq. zero clearing 29: freq. source A and K*B switch 30: freq. source A and A+K*B switch 31: freq. source A and A-K*B switch	1	7	×

## 4.1 Function Code

F7 Group - Digital Input and Output Parameters					
Function Code	Name	Set Range	Minimum Unit	Factory Default	Modification
F7.04	Input X5 function (when F8.21 is non-zero, default as function NO.62)	32: reserved 33: PID control input 34: PID control pause 35: start traverse operation 36: pause traverse operation 37: traverse status reset 38: PLC control input 39: PLC pause 40: PLC reset 41: clear the counter to zero 42: input signal to trigger the counter	1	8	×
F7.05	Input X6 function (when F8.21 is non-zero, default as function NO.63)	43: timing triggering input 44: timing clearing input 45: input external impulse frequency (only valid for X6) 46: clear the length information 47: input the signal of length (only valid for X6) 48: switch speed and torque control 49: prohibit torque control 50 ~ 55: reserved	1	0	×
F7.06	Input X7 function high speed impulse input	56 ~ 57: reserved 58: start/stop 59: running allowed 60: interlock1 61: interlock2 62: interlock3 63: PFC start/stop 64: A frequency switch B and run 65: First group PID switch to second group PID 66 ~ 69: reserved	1	45	×

## 4.1 Function Code

F7 Group - Digital Input and Output Parameters					
Function Code	Name	Set Range	Minimum Unit	Factory Default	Modification
F7.07	reserved	—	—	0	◆
F7.08	Digital filtering times	1 ~ 10 1: 2MS unit of scanning time	1	5	○
F7.09	Terminal function detection when power on	0: terminal operation command invalid when power on 1: terminal operation command valid when power on	1	0	○
F7.10	Effective logic setting of input terminal (X1 ~ X8)	0 ~ FFH 0 is positive logic, i.e. terminal Xi is enabled when it connects with common terminal and disabled if disconnected. 1 is negative logic, i.e. terminal Xi is disabled when it connects with common terminal and enabled when disconnected.	1	00	×
F7.11	FWD/REV terminal control mode	0: two-wire control mode 1 1: two-wire control mode 2 2: three-wire control mode 2 3: three-wire control mode 1	1	0	×
F7.12	UP/DOWN terminal frequency modifying rate	0.01 ~ 50.00Hz/s	0.01Hz/s	1.00	○
F7.13	reserved	—	—	0	◆
F7.14	Y1 output delay time	0.0 ~ 100.0s	0.1s	0.0	×
F7.15	Y2 output delay time	0.0 ~ 100.0s	0.1s	0.0	×
F7.16	R1 output delay time	0.0 ~ 100.0s	0.1s	0.0	×
F7.17	R2 output delay time (reserved)	0.0 ~ 100.0s	0.1s	0.0	×

## 4.1 Function Code

F7 Group - Digital Input and Output Parameters					
Function Code	Name	Set Range	Minimum Unit	Factory Default	Modification
F7.18	Open collector output terminal Y1	0: no output 1: VFD forward running 2: VFD reverse running 3: fault output 4: freq./speed level detection signal (FDT1) 5: freq./speed level detection signal (FDT2) 6: freq./speed arrival signal (FAR) 7: VFD zero-speed running 8: upper limit arrival of output freq. 9: lower limit arrival of output freq. 10: lower limit arrival of preset freq. during running 11: pre-alarm signal of overload 12: counter detection signal output 13: counter detection reset signal output	1	0	×
F7.19	Open collector output terminal Y2	14: driver ready 1 15: one cycle finished of programmable MS running 16: stage finished of programmable MS running 17: upper and lower limit of traverse freq. 18: current limiting action 19: stall over voltage 20: low voltage lock-up 21: dormancy state 22: VFD alarm signal (PID disconnection, RS485 communication failure, panel communication failure, EEPROM read-write failure, encoder disconnection, etc.) 23: AI1>AI2 24: preset length arrival 25: preset operation time out	1	0	×
F7.20	Programmable relay R1 output		1	3	×



## 4.1 Function Code

F7 Group - Digital Input and Output Parameters					
Function Code	Name	Set Range	Minimum Unit	Factory Default	Modification
F7.21	Programmable relay R2 output	26: dynamic braking action 27: DC braking action 28: fux braking action 29: torque limiting 30: over torque signal 31: auxiliary motor 1 32: auxiliary motor 2 33: accumulated operation time out 34 ~ 49: segment of MS or simple PLC operation 50: running indication signal 51: temperature arrival indication 52: indicate when VFD stops or runs at zero speed 53: reserved 54: reserved 55: communication setting 56: drive ready 2 57: The output indication signal is output when Al1 input over limit. 58 ~ 99: reserved	1	0	×
F7.22	Logic setting of output terminal (Y1 ~ Y2)	0~3H 0: positive logic, i.e. terminal Yi is enabled when it connects with common terminal, and disabled if disconnected. 1: negative logic, i.e. terminal Yi is disabled when it connects with common terminal, and enabled if disconnected.	1	0	×
F7.23	Freq. arrival detection range (FAR)	0.0 ~ 100.0% * 【F0.15】 max. freq.	0.1%	10.0%	○
F7.24	FDT1 detection method	0: speed set value 1: speed detected value	1	0	○

## 4.1 Function Code

F7 Group - Digital Input and Output Parameters					
Function Code	Name	Set Range	Minimum Unit	Factory Default	Modification
F7.25	FDT1 level	0.00Hz ~ 【F0.16】 upper limit freq.	0.01Hz	50.00	○
F7.26	FDT1 lag	0.0 ~ 100.0% * 【F7.25】	0.1%	2.0%	○
F7.27	FDT2 detection method	0: speed set value 1: speed detected value	1	0	○
F7.28	FDT2 level	0.00Hz ~ 【F0.16】 upper limit freq.	0.01Hz	25.00	○
F7.29	FDT2 lag	0.0 ~ 100.0% * 【F7.28】	0.1%	4.0%	○
F7.30	Counting value arrival processing	0: stop counting, stop output 1: stop counting, resume output 2: cycle count, stop output 3: cycle count, resume output	1	3	×
F7.31	Counting start condition	0: always count since power on 1: count in operation status, stop counting in stop status	1	1	×
F7.32	Counter reset value	【F7.33】 ~ 65535	1	0	○
F7.33	Counter detection value	0 ~ 【F7.32】	1	0	○
F7.34	time out processing	0: stop timing, stop output 1: stop timing, resume output 2: cycle timing, stop output 3: cycle timing, resume output	1	3	×
F7.35	Timing start condition	0: timing starts since power on 1: timing starts in operation status, and stops in stop status	1	1	×
F7.36	Timing setting	0 ~ 65535s	1s	0	○
F7.37	Y1 turn of delay time	0.0 ~ 100.0s	0.1s	0.0	×
F7.38	Y2 turn of delay time	0.0 ~ 100.0s	0.1s	0.0	×
F7.39	R1 turn of delay time	0.0 ~ 100.0s	0.1s	0.0	×
F7.40	R2 turn of delay time	0.0 ~ 100.0s	0.1s	0.0	×

## 4.1 Function Code

F8 Group - PID Control Parameters					
Function Code	Name	Set Range	Minimum Unit	Factory Default	Modification
F8.00	PID operation input mode	0: auto 1: manually input via defined multi-function terminal	1	0	×
F8.01	PID input channel	0: digital setting 1: AI1 2: AI2 3: pulse setting 4: RS485 communication 5: Reserved 6: Panel potentiometer setting	1	0	○
F8.02	Digital reference input setting	0.0 ~ 100.0%	0.1%	50.0%	○
F8.03	PID feedback channel	0: AI1 1: AI2 2: AI1+AI2 3: AI1-AI2 4: MAX {AI1, AI2} 5: MIN {AI1, AI2} 6: pulse setting 7: RS485 communication	1	0	○
F8.04	PID controller advanced setting	LED one's place: PID sign 0: positive 1: negative LED ten's place: proportion regulation (reserved) 0: integral regulation of constant proportion 1: integral regulation of auto changing proportion LED hundred's place: integral regulation 0: stop integral regulation when the frequency reaches the upper or lower limits 1: continue the integral regulation when the frequency reaches the upper or lower limits LED thousand's place: reserved	1	000	×

## 4.1 Function Code

F8 Group - PID Control Parameters					
Function Code	Name	Set Range	Minimum Unit	Factory Default	Modification
F8.05	Proportional gain KP1	0.01 ~ 100.00	0.01	2.5	○
F8.06	Integral time Ti1	0.01 ~ 10.00s	0.01s	0.10	○
F8.07	Derivative time Td1	0.01 ~ 10.00s 0.00: no derivation	0.01s	0.00	○
F8.08	Sampling cycle T	0.01 ~ 10.00s 0.00: auto	0.01s	0.10	○
F8.09	Error limit	0.0 ~ 100.0%	0.1%	0.0%	○
F8.10	Close-loop preset freq.	0.00 ~ upper limit freq.	0.01Hz	0.00	○
F8.11	Preset freq. hold time	0.0 ~ 3600.0s	0.1s	0.0	×
F8.12	Sleep mode	0: disabled 1: sleep when feedback pressure exceeding or lower than sleep threshold 2: sleep when feedback pressure and output frequency are stable	1	1	×
F8.13	Stop method of sleep mode	0: decelerate to stop 1: coast to stop	1.00	0	○
F8.14	Deviation limit of feedback when entering sleep state compared with set pressure	0.0 ~ 10.0% Note: this parameter is only valid to the second sleep mode.	0.1%	0.5%	○

## 4.1 Function Code

F8 Group - PID Control Parameters					
Function Code	Name	Set Range	Minimum Unit	Factory Default	Modification
F8.15	Threshold value of sleeping	0.0 ~ 200.0% Note: this threshold value is the percentage of given pressure, and it is only valid for the first sleep mode.	0.1%	100.0%	○
F8.16	Threshold value of awaking	0.0 ~ 200.0% Note: this threshold value is the percentage of given pressure.	0.1%	90.0%	○
F8.17	Delay time of sleep	0.0 ~ 3600.0s	0.1s	100.0	○
F8.18	Delay time of awaking	0.0 ~ 3600.0s	0.1s	5.0	○
F8.19	Delay time of adding pump	0.0 ~ 3600.0s	0.1s	10.0	○
F8.20	Delay time of reducing pump	0.0 ~ 3600.0s	0.1s	10.0	○
F8.21	Water supply enabling (F8.21-F8.24 not supported by hardware)	0: disabled 1: PFC enabled 2: SPFC enabled	1	0	×
F8.22	Delay time of terminal disconnect and connect	0.0 ~ 6000.0s	0.1s	0.1	○
F8.23	Polling time	0.0 ~ 6000.0h	0.1h	48.0	○
F8.24	Lower limit freq. of reducing pump	0.0 ~ 600.00Hz	0.01Hz	0.00	○
F8.34	Sleep frequency	0.00HZ ~ [F0.16]	0.01Hz	0.00	×

## 4.1 Function Code

F9 Group - MS and PLC Running, Traverse and Fixed Length Control					
Function Code	Name	Set Range	Minimum Unit	Factory Default	Modification
F9.00	PLC running mode	0: stop after single cycle 1: retain value after single cycle 2: continuous cycle of limited times 3: continuous cycle	1	0	×
F9.01	Input mode of PLC running	0: auto 1: manually input via defined multi-function terminal	1	0	×
F9.02	PLC running state saving after power of	0: not save 1: save the stage and frequency when power of	1	0	×
F9.03	PLC restart mode	0: restart from the first stage 1: start from the stage where the driver stops (fault) 2: start from the stage where the driver stops (fault) at the recorded frequency	1	0	×
F9.04	Limited times of continuous cycle	1 ~ 65535	1	1	○
F9.05	Unit of PLC running time	0: s 1: m	1	0	×
F9.06	MS frequency 0	-upper limit Freq. ~ upper limit Freq.	0.01Hz	5.00	○
F9.07	MS frequency 1	-upper limit Freq. ~ upper limit Freq.	0.01Hz	10.00	○
F9.08	MS frequency 2	-upper limit Freq. ~ upper limit Freq.	0.01Hz	15.00	○
F9.09	MS frequency 3	-upper limit Freq. ~ upper limit Freq.	0.01Hz	20.00	○
F9.10	MS frequency 4	-upper limit Freq. ~ upper limit Freq.	0.01Hz	25.00	○
F9.11	MS frequency 5	-upper limit Freq. ~ upper limit Freq.	0.01Hz	30.00	○
F9.12	MS frequency 6	-upper limit Freq. ~ upper limit Freq.	0.01Hz	40.00	○

## 4.1 Function Code

F9 Group - MS and PLC Running, Traverse and Fixed Length Control					
Function Code	Name	Set Range	Minimum Unit	Factory Default	Modification
F9.13	MS frequency 7	-upper limit Freq. ~ upper limit Freq.	0.01Hz	50.00	○
F9.14	MS frequency 8	-upper limit Freq. ~ upper limit Freq.	0.01Hz	0.00	○
F9.15	MS frequency 9	-upper limit Freq. ~ upper limit Freq.	0.01Hz	0.00	○
F9.16	MS frequency 10	-upper limit Freq. ~ upper limit Freq.	0.01Hz	0.00	○
F9.17	MS frequency 11	-upper limit Freq. ~ upper limit Freq.	0.01Hz	0.00	○
F9.18	MS frequency 12	-upper limit Freq. ~ upper limit Freq.	0.01Hz	0.00	○
F9.19	MS frequency 13	-upper limit Freq. ~ upper limit Freq.	0.01Hz	0.00	○
F9.20	MS frequency 14	-upper limit Freq. ~ upper limit Freq.	0.01Hz	0.00	○
F9.21	MS frequency 15	-upper limit Freq. ~ upper limit Freq.	0.01Hz	0.00	○
F9.22	Acc/Dec time of stage 0	0~3	1	0	○
F9.23	Run time of segment 0	0.0 ~ 65535.5s(M)	0.1s(M)	0.0	○
F9.24	Acc/Dec time of stage 1	0~3	1	0	○
F9.25	Run time of stage 1	0.0 ~ 65535.5s(M)	0.1s(M)	0.0	○
F9.26	Acc/Dec time of stage 2	0~3	1	0	○
F9.27	Run time of stage 2	0.0 ~ 65535.5s(M)	0.1s(M)	0.0	○
F9.28	Acc/Dec time of stage 3	0~3	1	0	○
F9.29	Run time of stage 3	0.0 ~ 65535.5s(M)	0.1s(M)	0.0	○
F9.30	Acc/Dec time of stage 4	0~3	1	0	○
F9.31	Run time of stage 4	0.0 ~ 65535.5s(M)	0.1s(M)	0.0	○
F9.32	Acc/Dec time of stage 5	0~3	1	0	○

## 4.1 Function Code

F9 Group - MS and PLC Running, Traverse and Fixed Length Control					
Function Code	Name	Set Range	Minimum Unit	Factory Default	Modification
F9.33	Run time of stage 5	0.0 ~ 65535.5s(M)	0.1s(M)	0.0	○
F9.34	Acc/Dec time of stage 6	0~3	1	0	○
F9.35	Run time of stage 6	0.0 ~ 65535.5s(M)	0.1s(M)	0.0	○
F9.36	Acc/Dec time of stage 7	0~3	1	0	○
F9.37	Run time of stage 7	0.0 ~ 65535.5s(M)	0.1s(M)	0.0	○
F9.38	Acc/Dec time of stage 8	0~3	1	0	○
F9.39	Run time of stage 8	0.0 ~ 65535.5s(M)	0.1s(M)	0.0	○
F9.40	Acc/Dec time of stage 9	0~3	1	0	○
F9.41	Run time of stage 9	0.0 ~ 65535.5s(M)	0.1s(M)	0.0	○
F9.42	Acc/Dec time of stage 10	0~3	1	0	○
F9.43	Run time of stage 10	0.0 ~ 65535.5s(M)	0.1s(M)	0.0	○
F9.44	Acc/Dec time of stage 11	0~3	1	0	○
F9.45	Run time of stage 11	0.0 ~ 65535.5s(M)	0.1s(M)	0.0	○
F9.46	Acc/Dec time of stage 12	0~3	1	0	○
F9.47	Run time of stage 12	0.0 ~ 65535.5s(M)	0.1s(M)	0.0	○
F9.48	Acc/Dec time of stage 13	0~3	1	0	○
F9.49	Run time of stage 13	0.0 ~ 65535.5s(M)	0.1s(M)	0.0	○
F9.50	Acc/Dec time of stage 14	0~3	1	0	○
F9.51	Run time of stage 14	0.0 ~ 65535.5s(M)	0.1s(M)	0.0	○
F9.52	Acc/Dec time of stage 15	0~3	1	0	○
F9.53	Run time of stage 15	0.0 ~ 65535.5s(M)	0.1s(M)	0.0	○
F9.54	Reserved	—	—	0	◆
F9.55	Traverse control	0: disabled 1: enabled	1	0	×
F9.56	Input method of traverse mode	0: auto 1: manually input via defined multi-function terminal	1	0	×



#### 4.1 Function Code

F9 Group - MS and PLC Running, Traverse and Fixed Length Control					
Function Code	Name	Set Range	Minimum Unit	Factory Default	Modification
F9.57	Amplitude control	0: fixed amplitude 1: varied amplitude	1	0	×
F9.58	Restart method of traverse mode	0: start to the state before stop 1: restart without other requirement	1	0	×
F9.59	Save traverse state upon power failure	0: save 1: not save	1	0	×
F9.60	Preset traverse freq.	0.00Hz ~ upper limit Freq.	0.01Hz	10.00	○
F9.61	Preset traverse freq. hold time	0.0 ~ 3600.0s	0.1s	0.0	×
F9.62	Traverse amplitude	0.0 ~ 100.0%	0.1%	0.0%	○
F9.63	Step freq.	0.0 ~ 50.0% (of amplitude)	0.1%	0.0%	○
F9.64	Traverse rising time	0.1 ~ 3600.0s	0.1s	5.0	○
F9.65	Traverse falling time	0.1 ~ 3600.0s	0.1s	5.0	○
F9.66	reserved	—	—	0	◆
F9.67	Length control	0: disabled 1: enabled	1	0	×
F9.68	Preset length	0.000 ~ 65.535(KM)	0.001KM	0.000	○
F9.69	Actual length	0.000 ~ 65.535(KM)	0.001KM	0.000	○
F9.70	Length factor	0.100 ~ 30.000	0.001	1.000	○
F9.71	Length calibration	0.001 ~ 1.000	0.001	1.000	○
F9.72	Shaft circumference	0.10 ~ 100.00CM	0.01CM	10.00	○
F9.73	Pulse per revolution (X7)	1 ~ 65535	1	1024	○

#### 4.1 Function Code

FA Group - Protective Parameters					
Function Code	Name	Set Range	Minimum Unit	Factory Default	Modification
FA.00	Motor overload protection	0: disabled 1: common motor (electronic heat relay, with low speed compensation) 2: variable frequency motor (electronic heat relay, without low speed compensation)	1	1	×
FA.01	Motor overload protection factor	20.0% ~ 120.0%	0.1%	100.0%	×
FA.02	Under voltage protection	0: disabled 1: enabled (undervoltage is seen as fault)	1	0	×
FA.03	Under voltage protection level	220V: 180 ~ 280V 200V 380V: 330 ~ 480V 350V	1V	Depending on model	×
FA.04	Over voltage limit level	220V: 350 ~ 390V 370V 380V: 600 ~ 780V 660V	1V	Depending on model	×
FA.05	Voltage limit factor in decelerating	0 ~ 100 0: protection invalid of stall over voltage	1	Depending on model	×
FA.06	Current limiting threshold (only valid for VF mode)	G type: 80% ~ 200% *VFD rated current 160% P type: 80% ~ 200% *VFD rated current 120%	1%	Depending on model	×
FA.07	Current limiting in the field weakening region	0: limited by FA.06 1: limited by conversion value of PA.06	1	0	×
FA.08	Current limiting factor in accelerating	0 ~ 100 0: acceleration current limiting is disabled	1	Depending on model	×
FA.09	Current limiting in constant speed running	0: disabled 1: enabled	1	1	×
FA.10	Of load detection time	0.1S ~ 60.0s	0.1s	5.0	○
FA.11	Of load detection level	0 ~ 100%*VFD rated current 0: of load detection is disabled	1%	0%	○

#### 4.1 Function Code

FA Group - Protective Parameters					
Function Code	Name	Set Range	Minimum Unit	Factory Default	Modification
FA.12	Overload pre-alarm level	G type: 20% ~ 200% *VFD rated current 160% P type: 20% ~ 200% *VFD rated current 120%	1%	Depending on model	○
FA.13	Overload pre-alarm delay time	0.0 ~ 300s	0.1s	10.0	○
FA.14	Temperature detection threshold	0.0°C ~ 90.0°C	0.1°C	65.0°C	×
FA.15	Phase loss protection of input and output	0: disabled 1: disabled for input, enabled for output 2: enabled for input, disabled for output 3: enabled	1	Depending on model	×
FA.16	Delay time of input phase loss protection	0.0 ~ 30.0s	0.1S	1.0	○
FA.17	Detection reference of output phase loss protection	0% ~ 100% *VFD rated current	1%	50%	×
FA.18	Detection factor of output current imbalance	1.00 ~ 10.00 1.00: imbalance detection is disabled Note: detection of output current imbalance and output phase loss share the same reference parameter FA.17 and fault code E-13.	—	1.00	×
FA.19	reserved	—	—	0	◆
FA.20	PID feedback disconnection processing	0: disabled 1: alarm and maintain the operation at the frequency of disconnection moment 2: protection action and coast to stop 3: alarm and decelerate to zero-speed operation according to preset mode	1	0	×

#### 4.1 Function Code

FA Group - Protective Parameters					
Function Code	Name	Set Range	Minimum Unit	Factory Default	Modification
FA.21	Feedback disconnection detection value	0.0 ~ 100.0%	0.1%	0.0%	○
FA.22	Feedback disconnection detection time	0.0 ~ 3600.0s	0.1s	10.0	○
FA.23	reserved	—	—	0	◆
FA.24	Action of R5485 communication error	0: protection action and coast to stop 1: alarm and maintain the current operation 2: alarm and stop according to the preset mode	1	1	×
FA.25	RS485 communication timeout detect	0.0: no detect 0.1 ~ 100.0s note: communication time out detection is disabled in stop status	0.1s	5.0	○
FA.26	Action of operation panel communication error	0: protection action and coast to stop 1: alarm and maintain the current operation 2: protection action and stop according to the preset stop mode	1	1	×
FA.27	Operation panel communication timeout detect	0.0 ~ 100.0s	0.1s	1.0	○
FA.28	Action of EEPROM read-write error	0: protection action and coast to stop 1: alarm and maintain the current operation	1	0	×
FA.29-FA.35	reserved	—	—	0	◆

## 4.1 Function Code

FB Group - RS485 Communication Parameters					
Function Code	Name	Set Range	Minimum Unit	Factory Default	Modification
FB.00	Protocol	0: MODBUS 1: user-defined	1	0	×
FB.01	Local address	0: broadcast address 1 ~ 247: slave	1	1	×
FB.02	Baud rate setting	0: 2400BPS 1: 4800BPS 2: 9600BPS 3: 19200BPS 4: 38400BPS 5: 115200BPS	1	3	×
FB.03	Data format	0: no parity (N, 8, 1) for RTU 1: even parity (E, 8, 1) for RTU 2: odd parity (O, 8, 1) for RTU 3: no parity (N, 8, 2) for RTU 4: even parity (E, 8, 2) for RTU 5: odd parity (O, 8, 2) for RTU ASCII mode is reserved at present	1	0	×
FB.04	Response delay	0 ~ 200ms	1ms	5	×
FB.05	Transmission response	0: response for write operation 1: no response for write operation	1	0	×
FB.06	Ratio correlation coefficient	0.01 ~ 10.00	0.01	1.00	○

## 4.1 Function Code

FC Group - Advanced Function and Performance Parameters					
Function Code	Name	Set Range	Minimum Unit	Factory Default	Modification
FC.00	Dynamic braking	0: disabled 1: always enabled 2: only enabled when decelerating	1	2	×
FC.01	Initial voltage of dynamic braking	220V: 340 ~ 380V 360V 380V: 660 ~ 760V 680V	1V	Depending on model	○
FC.02	Hysteresis voltage of dynamic braking	220V: 10 ~ 100V 5V 380V: 10 ~ 100V 10V	1V	Depending on model	○
FC.03	Action ratio of dynamic braking	10 ~ 100%	1%	100%	○
FC.04	Restart after power failure	0: disabled 1: start at start frequency 2: start in speed tracking mode	1	0	×
FC.05	Restart delay after power failure	0.0 ~ 60.0s	0.1s	5.0	×
FC.06	Auto reset times	0 ~ 100 the setting value of 100 means unlimited times	1	0	×
FC.07	Auto reset interval	0.1 ~ 6000m	0.1	3.0	×
FC.08	Cooling fan control	0: auto control mode 1: always running when power on	1	0	○
FC.09	Password of operation limiting function	0 ~ 65535 Note 1: the password will take into effect 3 minutes later after set successfully Note 2: this parameter cannot be initialized.	1	0	○
FC.10	Operation limiting function	0: disabled 1: enabled Note: this parameter cannot be initialized	1	0	○
FC.11	Limiting time	0 ~ 65535(h) Note: this parameter cannot be initialized	1	0	×
FC.12	Freq. decreasing point of instantaneous power failure	220V: 180 ~ 330V 250V 380V: 300 ~ 550V 450V	1V	Depending on model	×

#### 4.1 Function Code

FC Group - Advanced Function and Performance Parameters					
Function Code	Name	Set Range	Minimum Unit	Factory Default	Modification
FC.13	Freq. decreasing factor of instantaneous power failure	0: the function of immunity to transient power failure is disabled 1 ~ 100	1	0	○
FC.14	Droop control	0.00 ~ 10.00Hz 0.00: droop control function is disabled	0.01Hz	0.00	×
FC.15	Delay time of rotating speed tracking	0.1 ~ 5.0s	0.1s	1.0	×
FC.16	Current amplitude limiting of rotating speed tracking	80% ~ 200% *VFD rated current	1%	100%	×
FC.17	Speed of rotating speed tracking	1 ~ 125	1	25	×
FC.18	PWM mode	LED one's place: PWM synthesize method 0: seven segments of full band 1: switch from 7 segment to five segments LED ten's place: PWM temperature correlation 0: disabled 1: enabled LED hundred's place: PWM frequency correlation 0: disabled 1: low freq. adjustment, high Freq. adjustment 2: no adjustment for low freq., high freq. adjustment 3: low freq. adjustment, no adjustment for high freq. LED thousand's place: flexible PWM function 0: disabled 1: enabled	1	0001	×

#### 4.1 Function Code

FC Group - Advanced Function and Performance Parameters					
Function Code	Name	Set Range	Minimum Unit	Factory Default	Modification
FC.19	AVR function	LED one's place: AVR function 0: disabled 1: always enabled 2: only disabled when decelerating LED ten's place: overmodulation 0: disabled 1: enabled LED hundred's place: dead-time compensation 0: disabled 1: enabled LED thousand's place: harmonic components optimizing (reserved) 0: disabled 1: enabled	1	1102	×
FC.20	Oscillation suppressing initial freq.	0.00 ~ 300.00Hz	0.01	Depending on model	○
FC.21	Flux braking	0 ~ 100 0: disabled	1	0	○
FC.22	Energy saving control factor	0 ~ 100 0: disabled	1	0	○
FC.23	MS priority	0: disabled 1: MS prior to F0.07 setting	1	0	×



## 4.1 Function Code

FC Group - Advanced Function and Performance Parameters					
Function Code	Name	Set Range	Minimum Unit	Factory Default	Modification
FC.24	Jog priority	0: disabled 1: the jog has the highest priority during the driver operation	1	0	×
FC.25	Special function	LED one's place: A02 and D0 output selection 0: A02 enabled 1: D0 enabled LED ten's place: OC function (reserved) 0: disabled 1: enabled LED hundred's place: OU1 function (reserved) 0: disabled 1: enabled LED thousand's place: reserved	1	10	×
FC.26	Oscillation suppression upper limit freq.	0.00 ~ 300.00Hz	0.01	50.00	○
FC.27	Oscillation suppression coefcient	1 ~ 500	1	50	○
FC.28	Oscillation suppression voltage	0.0 ~ 25.0%*motor rated voltage	0.1%	5.0	○

## 4.1 Function Code

FD Group - Pump Use Parameter					
Function Code	Name	Set Range	Minimum Unit	Factory Default	Modification
FD.00	Special function of software	0: General function 1: Solar use for pump 2: constant pressure water supply use Note: When Fd.00 = 2, set sensor range at F8.25 and pressure at F8.26.	1	0	×
FD.01	MPPT upper limit voltage	380V: [Fd.01] ~ 1000 537V 220V: [Fd.01] ~ 500 311V	1V	Depending on model	○
FD.02	MPPT lower limit voltage	380V: 0 ~ [Fd.00] 350V 220V: 0 ~ [Fd.00] 200V	Depending on model	Depending on model	○
FD.03	Lowest running frequency when yielding water	0.00Hz ~ [F0.16]	0.01	20	○
FD.04	Water shortage detection current ratio corresponding to no-load current	80.0 ~ 300.0%* [F2.10]	0.1%	150	○
FD.05	Water shortage detection time	0 ~ 250s	1	10	○
FD.06	Power on auto start delay	0 ~ 65535s	1	0	○
FD.07	Antifreeze function	0: turn of 1: turn on, clock in second 2: turn on, clock in minute	1	0	×
FD.08	Antifreeze action interval	0 ~ 9999s/min	1s/min	300	○
FD.09	Antifreeze protection action frequency	0.00 ~ upper limit frequency	0.1Hz	10.00	○
FD.10	Antifreeze protection action time	0 ~ 9999s/min	1s/min	60	○
FD.11	High pressure alarm setting value	Pressure setting ~ sensor range	0.1Bar	9.0	○
FD.12	Low pressure alarm setting value	0.0 ~ water shortage detection threshold	0.1Bar	0.0	○
FD.13	Abnormal pressure alarm delay time	0 ~ 65535s Note: high pressure and low pressure alarm delay time	0.1s	3	○
FD.14	On-line function selection	0: invalid 1: valid	1	0	○
FD.15	Rotation interval	0 ~ 65535H	1H	72	○

## 4.1 Function Code

FE Group - Panel Function Setting and Parameter Management					
Function Code	Name	Set Range	Minimum Unit	Factory Default	Modification
FE.00	LCD language option (only for LCD panel)	0: Chinese 1: English 2: reserved	1	0	○
FE.01	Key M-FUNC function	0: JOG (jog control) 1: FWD/REV switch 2: clear frequency set by ▲/▼ 3: switch between local operation and remote control (reserved) 4: reverse	1	0	×
FE.02	Key STOP/RST function	0: only effective to panel control 1: effective to both panel and terminal control 2: effective to both panel and communication control 3: effective to all control modes	1	3	○
FE.03	STOP+RUN emergency stop	0: disabled 1: coast to stop	1	1	○
FE.04	Close-loop display factor	0.01 ~ 100.00	0.01	1.00	○
FE.05	Display factor of load rotating speed	0.01 ~ 100.00	0.01	1.00	○
FE.06	Line speed factor	0.01 ~ 100.00	0.01	1.00	○
FE.07	Encoder regulation speed (served)	1 ~ 100	1	70	○
FE.08	Monitoring parameter selection 1 in operation status	0~57	1	0	○
FE.09	Monitoring parameters selection 2 in operation status	0~57	1	5	○

## 4.1 Function Code

FE Group - Panel Function Setting and Parameter Management					
Function Code	Name	Set Range	Minimum Unit	Factory Default	
FE.10	Monitoring parameters selection 1 in stop status	0~57	1	1	○
FE.11	Monitoring parameters selection 2 in stop status	0~57	1	12	○
FE.12	Parameter display mode	LED one's place: function parameters display mode 0: display all function parameters 1: only display parameters diferent from default value 2: only display parameters modified after power on of the last time (reserved) LED ten's place: monitoring parameters display mode 0: only display main monitoring parameters 1: alternate display of main and auxiliary paramete rs (inte rval time 1S) LED hundred's place and thousand's place: reserved	1	00	○
FE.13	Parameter initialization	0: disabled 1: restore to factory defaults (all user parameters except motor parameters) 2: restore to factory defaults (all user parameters) 3: clear fault record	1	0	×

#### 4.1 Function Code

FE Group - Panel Function Setting and Parameter Management					
Function Code	Name	Set Range	Minimum Unit	Factory Default	Modification
FE.14	Write-protect	0: allow all parameters to be modified some are not during operation) 1: only allow F0.12, F0.13 and F0.14 to be modified 2: only allow FE.14 to be modified Note: these above limitations are invalid to this function code and F0.00	1	0	○
FE.15	Parameter copy function	0: disabled 1: parameters upload to operation panel 2: all function code parameters download to the driver 3: download all function code parameters except motor parameters to the driver Note1: when selecting parameters to download, the software will check if it is in accordance with the driver power specification; if not, all the parameters relevant to model will not be changed. Note2: only keyboard KB2 has copy function, copy with normal keyboard will increase fault.	1	0	×

#### 4.1 Function Code

FF Group - Factory Parameter					
Function Code	Name	Set Range	Minimum Unit	Factory Default	Modification
FF.00	Factory Password	0 ~ 65535 Note: After password setup was successful, it will take 3 minutes to take effect	1	0	○
FF.01	Reserved	—	—	0	◇
FF.02	VFD Model	0~30 0: 0.4KW 1: 0.75KW 2: 1.5KW 3: 2.2KW 4: 4.0KW 5: 5.5KW 6: 7.5KW 7: 11KW 8: 15KW 9: 18.5KW 10: 22KW 11: 30KW 12: 37KW 13: 45KW 14: 55KW 15: 75KW 16: 90KW 17: 110KW 18: 132KW 19: 160KW 20: 185KW 21: 200KW 22: 220KW 23: 250KW 24: 280KW 25: 315KW 26: 350KW 27: 375KW 28: 400KW 29: 500KW 30: 630KW	1	Model Dependant	◇
FF.03	Rated Power	0.4 ~ 999.9KW Note: this parameter can only be viewed	0.1KW	Model Dependant	◇
FF.04	Rated Voltage	0 ~ 999V	1V	380	◇
FF.05	Rated Current	0.1 ~ 6553.5A	0.1A	Model Dependant	◇
FF.06	Dead Zone Time	3.2 ~ 10.0μS 0.4 ~ 4.0KW 3.2μS 5.5 ~ 22KW 3.5μS 30 ~ 110KW 4.0μS 132 ~ 630KW 4.5μS	0.1μS	Model Dependant	◇
FF.07	Software Overvoltage Point	220V:0 ~ 450V 400V 380V:0 ~ 850V 800V	1V	Model Dependant	◇
FF.08	Software Undervoltage Point	220V:0 ~ 280V 150V 380V:0 ~ 320V 250V	1V	Model Dependant	◇
FF.09	Software Overcurrent Point	50.0 ~ 250.0%	0.1%	220.0%	◇
FF.10	Voltage Correction Factor	80.0 ~ 120.0%	0.1%	100.0%	◇
FF.11	Current Correction Factor	50.0 ~ 150.0%	0.1%	100.0%	◇

## 4.1 Function Code

FF Group - Factory Parameter					
Function Code	Name	Set Range	Minimum Unit	Factory Default	Modification
FF.12	Temperature Detection Mode Selection	0: type I 1: type II	1	0	◇
FF.13	First Temperature Sensor Protection Threshold	50.0°C~90.0°C	0.1°C	85.0	◇
FF.14	Second Temperature Sensor Protection Threshold	50.0°C~90.0°C	0.1°C	85.0	◇
FF.15	Special information clarity function	0: forbidden 1: clear cumulative operating time 2: clear cumulative power time 3: clear fan cumulative operation time 4: clear cumulative power consumption	1	0	◇
FF.16	Factory Bar Code 1	0 ~ 65535	1	0	◇
FF.17	Factory Bar Code 2	0 ~ 65535	1	0	◇
FF.18	Manufacture Date(Mon, Day)	0 ~ 1231	1	0	◇
FF.19	Manufacture Date(Year)	2010 ~ 2100	1	2013	◇
FF.20	Software Upgrade Date (Mon, Day)	0 ~ 1231	1	0716	◇
FF.21	Software Upgrade Date (Year)	2010 ~ 2100	1	2018	◇
FF.22	Special Function Selection	Led unit's place: inverter prohibited G / P model selection 0: invalid 1: efective Led ten's place: current direction selection 0: forward (pointing motor) 1: reverse (pointing inverter) Led hundred's place: system power choice 0: 5v 1: 3.3v Led thousand's place: reserved 0: resered 1: resered	1	000	◇

## 4.2 Detailed Function Description

### Monitoring Parameter

D-00	Output frequency (before slip compensation)	0.00 ~ max. output freq.【F0.15】	0.00
D-01	Output frequency (after slip compensation)	0.00 ~ max. output freq.【F0.15】	0.00
D-02	Estimated Motor Frequency	0.00 ~ max. output freq.【F0.15】	0.00
D-03	Main Set Frequency	0.00 ~ max. output freq.【F0.15】	0.00
D-04	Auxiliary Set Frequency	0.00 ~ max. output freq.【F0.15】	0.00
D-05	Output Current	0.0 ~ 6553.5A	0.0
D-06	Output Voltage	0 ~ 999V	0
D-07	Output Torque	-200.0 ~ 200.0%	0.0%
D-08	Motor Revolving Speed (RPM/min)	0 ~ 36000RPM/min	0
D-09	Motor Power Factor	0.00 ~ 1.00	0.00
D-10	Run Linear Velocity (m/s)	0.01 ~ 655.35m/s	0.00
D-11	Set Linear Velocity (m/s)	0.01 ~ 655.35m/s	0.00
D-12	Bus voltage (V)	0 ~ 999V	0
D-13	Input voltage (V)	0 ~ 999V	0
D-14	PID Set Value (V)	0.00 ~ 10.00V	0.00
D-15	PID Feedback (V)	0.00 ~ 10.00V	0.00
D-16	Analog Input AI1	0.00 ~ 10.00V	0.00
D-17	Analog Input AI2	0.00 ~ 10.00V	0.00
D-18	Impulse Frequency Input	0.0 ~ 50.0kHz	0.00
D-19	Analog Output AO1	0.00 ~ 10.00V	0.00
D-20	Analog Output AO2	0.00 ~ 10.00V	0.00
D-21	Input Terminal Status	0 ~ FFH	0



## 4.2 Detailed Function Description

D-22	Output Terminal Status	
	0~FH	0

D-23	VFD Running Status	
	0 ~ FFFFH	0

O ~ FFFFH

BIT0: run/stop

BIT1: reverse/forward

BIT2: zero-speed running

BIT3: reserved

BIT4: accelerating

BIT5: decelerating

BIT6: constant speed running

BIT7: pre-excitation

BIT8: tuning of VFD parameter

BIT9: overcurrent limit

BIT10: overvoltage limit

BIT11: amplitude limiting of torque

BIT12: amplitude limiting of speed

BIT13: speed control

BIT14: torque control

BIT15: reserved

D-24	Current stage of multistage speed	
	0~15	0

D-25	reserved	
	—	0

D-26	reserved	
	—	0

D-27	Current count value	
	0 ~ 65535	0

D-28	Set count value	
	0 ~ 65535	0

D-29	Current timing value (S)	
	0 ~ 65535S	0

D-30	Set timing value (S)	
	0 ~ 65535S	0

D-31	Current length	
	0.000 ~ 65.535(KM)	0.000

D-32	Set length	
	0.000 ~ 65.535(KM)	0.000

D-33	radiator (IGBT) temperature 1	
	0.0°C ~ +1 10.0°C	0.0

D-34	radiator (IGBT) temperature 2	
	0.0°C ~ +1 10.0°C	0.0

D-35	accumulative run time of VFD (hour)	
	0 ~ 65535H	0

D-36	accumulative power-on time of VFD (hour)	
	0 ~ 65535H	0

D-37	accumulative run time of fan (hour)	
	0 ~ 65535H	0

D-38	Accumulative electricity consumption (low order digit)	
	0 ~ 9999KWH	0

## 4.2 Detailed Function Description

D-39	Accumulative electricity consumption (high order digit)	
	0 ~ 9999KWH (*10000)	0

D-40	Special model monitoring parameter (reserved)	
	reserved	0.00

D-41	Special model monitoring parameter (reserved)	
	reserved	0.0

D-42	Special model monitoring parameter (reserved)	
	reserved	0

D-43	Special model monitoring parameter (reserved)	
	reserved	0

D-44	Special model monitoring parameter (reserved)	
	reserved	0

D-45	Special model monitoring parameter (reserved)	
	reserved	0

D-46	Special model monitoring parameter (reserved)	
	reserved	0

D-47	Special model monitoring parameter (reserved)	
	reserved	0

D-48	The third to last fault type	
	0~30	0

D-49	The second to last fault type	
	0~30	0

D-50	Last fault type	
	0~30	0

D-51	Current fault type	
	0~30	0

D-52	Run frequency of current fault	
	0.00 ~ 【F0.16】 upper limit freq.	0.00

D-53	Output current of current fault	
	0.0 ~ 6553.5A	0.0

D-54	Busbar voltage of current fault	
	0 ~ 999V	0

D-55	Input terminal status of current fault	
	0 ~ FFH	0

D-56	Output terminal status of current fault	
	0~FH	0

D-57	Run state of current fault	
	0 ~ FFFFH	0

## 5 Communication Protocol

### 5.1 RTU mode and format

When controller communicates via Modbus in RTU mode, each byte is divided into 2 hexadecimal characters of 4 bits. The main advantage of this mode is that it can transfer characters with higher density compared with ASCII mode given the condition of the same baud rate, and each information must be transported continuously.

#### 1) each byte format in RTU mode

Encoding system: 8 bits binary, hexadecimal 0-9, A-F.

Data bits: 1 bit of start bit, 8 bits of data (send from the lower bit), 1 bit of stop bit, optional parity check bit (refer to bit sequence of RTU data frame).

Error check zone: cyclic redundancy check (CRC).

#### 2) Bit sequence of RTU data frame

With parity check

Start	1	2	3	4	5	6	7	8	FAr	Stop
-------	---	---	---	---	---	---	---	---	-----	------

Without parity check

Start	1	2	3	4	5	6	7	8	Stop
-------	---	---	---	---	---	---	---	---	------

### 5.2 Register Address and Function Code

#### 1) supported function code

Function code	Function description
03	Read multiple registers
06	Write single register
10	Write multiple registers continuously
13	Read single parameter

## Communication Protocol

### 2) register address

Register function	Address
Control command input	0x2000
Read monitor parameter	0xD000 (0x1D00) ~ 0xD039 (0x1D39)
MODBUS frequency setting	0x2001
MODBUS torque setting	0x2002
MODBUS PID frequency given	0x2003
MODBUS PID feedback setting	0x2004
MODBUS analog output AO1 control	0x2005 (0 ~ 7FFF indicates 0% ~ 100%)
MODBUS analog output AO2 control	0x2006 (0 ~ 7FFF indicates 0% ~ 100%)
MODBUS pulse DO output control	0x2007 (0 ~ 7FFF indicates 0% ~ 100%)
MODBUS digital output terminal control	0x2008 (0 ~ 7FFF indicates 0% ~ 100%)
Parameter setting	0x0000 ~ 0x0F15

### 3) 03H read multiple parameters (8 items continuously at most)

Inquiry information frame format (send frame) :

Address	01H
Function	03H
Starting data address	00H
	01H
Number of Data(Byte)	00H
	02H
CRC CHK High	95H
CRC CHK Low	CBH

Analysis of this segment data:

01H is the address of the driver

03H read function code

0001H is start address, equivalent to F0.01 of control panel

0002H is item count of menu, i.e. the two items of F0.01 and F0.02

95CBH is 16 bits of CRC check code

## Communication Protocol

Response information frame format (return frame):

Address	01H
Function	03H
DataNum*2	04H
Data1[2Byte]	00H
	64H
Data2[2Byte]	00H
	64H
CRC CHK High	BAH
CRC CHK Low	07H

Analysis of this segment data:

- 01H is the address of the driver
- 03H read function code
- 04H is the product of (read item)\*2
- 0064H read the data of F0.01
- 0064H read the data of F0.02
- BA07H is 16 bits of CRC check code

Example:

Name	Frame format
Read data of F0.01 and F0.02	Send frame: 01H 03H 0001H 0002H 95CBH
	Return frame: 01H 03H 04H 0064H 0064H BA07H
Read data of F2.01	Send frame: 01H 03H 0201H 0001H D472H
	Return frame: 01H 03H 02H 000FH F840H
Read monitor parameter of d-00 (address D000H and 1D00H interchangeable)	Send frame: 01H 03H D000H 0001H BCCAH
	Return frame: 01H 03H 02H 1388H B512H
	Send frame: 01H 03H 1D00H 0001H 8266H
	Return frame: 01H 03H 02H 1388H B512H
Read the status when the driver stops (address A000H and 1A00H interchangeable, refer to the run status description of the driver)	Send frame: 01H 03H A000H 0001H A60AH
	Return frame: 01H 03H 02H 0040H B9B4H
	Send frame: 01H 03H 1A00H 0001H 8312H
	Return frame: 01H 03H 02H 0040H B9B4H

## Communication Protocol

Example:

Name	Frame format
Read fault code E-19 (address E000H and 1E00H interchangeable, refer to the fault code table)	Send frame: 01H 03H E000H 0001H B3CAH
	Return frame: 01H 03H 02H 0013H F989H
	Send frame: 01H 03H 1E00H 0001H 8222H
	Return frame: 01H 03H 02H 0013H F989H
Read pre-alarm code A-18 (address E001H and 1E01 interchangeable, refer to the pre-alarm code table)	Send frame: 01H 03H E001H 0001H E20AH
	Return frame: 01H 03H 02H 0012H 3849H
	Send frame: 01H 03H 1E01H 0001H D3E2H
	Return frame: 01H 03H 02H 0012H 3849H

4) 06H write single parameter

Inquiry information frame format (send frame):

Address	01H
Function	06H
Starting data address	20H
	00H
Data(2Byte)	00H
	01H
CRC CHK Low	43H
CRC CHK High	CAH

Analysis of this segment data:

- 01H is the address of the driver
- 06H write function code
- 2000H is the address of control command
- 0001H is forward command
- 43A1H is 16 bits of CRC check code

## Communication Protocol

Response information frame format (Return frame) :

Address	01H
Function	06H
Starting data address	20H
	00H
Number of Data(Byte)	00H
	01H
CRC CHK High	43H
CRC CHK Low	CAH

Analysis of this segment data: if set right, return the same input data

Example:

Name	Frame format
forward	Send frame: 01H 06H 2000H 0001H 43CAH
	Return frame: 01H 06H 2000H 0001H 43CAH
reverse	Send frame: 01H 06H 2000H 0009H 420CH
	Return frame: 01H 06H 2000H 0009H 420CH
stop	Send frame: 01H 06H 2000H 0003H C20BH
	Return frame: 01H 06H 2000H 0003H C20BH
Free stop	Send frame: 01H 06H 2000H 0004H 83C9H
	Return frame: 01H 06H 2000H 0004H 83C9H
reset	Send frame: 01H 06H 2000H 0010H 43CAH
	Return frame: 01H 06H 2000H 0010H 43CAH
Forward jog	Send frame: 01H 06H 2000H 0002H 03CBH
	Return frame: 01H 06H 2000H 0002H 03CBH
Reverse jog	Send frame: 01H 06H 2000H 000AH 020DH
	Return frame: 01H 06H 2000H 000AH 020DH

## Communication Protocol

Example:

Name	Frame format
Set F8.00 parameter at 1	Send frame: 01H 06H 0800H 0001H 4A6AH
	Return frame: 01H 06H 0800H 0001H 4A6AH
MODBUS reference frequency 40HZ	Send frame: 01H 06H 2001H 0FA0H D642H
	Return frame: 01H 06H 2001H 0FA0H D642H
MODBUS PID reference 5V	Send frame: 01H 06H 2003H 01F4H 721DH
	Return frame: 01H 06H 2003H 01F4H 721DH
MODBUS PID feedback 4V	Send frame: 01H 06H 2004H 0190H C237H
	Return frame: 01H 06H 2004H 0190H C237H
MODBUS torque set at 80%	Send frame: 01H 06H 2002H 0320H 22E2H
	Return frame: 01H 06H 2002H 0320H 22E2H
User password check (address AD00H and 1C00H interchangeable)	Send frame: 01H 06H AD00H 0001H 68A6H
	Return frame: 01H 06H AD00H 0001H 68A6H
	Send frame: 01H 06H 1C00H 0001H 4F9AH
	Return frame: 01H 06H 1C00H 0001H 4F9AH
Check operation limit password (address AD01H and 1C01H interchangeable)	Send frame: 01H 06H AD01H 0002H 7967H
	Return frame: 01H 06H AD01H 0002H 7967H
	Send frame: 01H 06H 1C01H 0002H 5E5BH
	Return frame: 01H 06H 1C01H 0002H 5E5BH

## Communication Protocol

5) 10H write multiple parameters continuously

Inquiry information frame format (send frame):

Address	01H
Function	10H
Starting data address	01H
	00H
Number of Data(Byte)	00H
	02H
DataNum*2	04H
Data1(2Byte)	00H
	01H
Data2(2Byte)	00H
	02H
CRC CHK High	2EH
CRC CHK Low	3EH

Analysis of this segment data:

01H is the address of the driver

10H write function code

0100H start address, equivalent to F1.00 of control panel

0002H amount of registers

04H bytes sum (2\*register amount)

0001H data of F1.00

0002H data of F1.01

2E3EH 16 bits of CRC check code

## Communication Protocol

Response information frame format (Return frame) :

Address	01H
Function	10H
Starting data address	01H
	00H
Number of Data(Byte)	00H
	02H
CRC CHK High	40H
CRC CHK Low	34H

Analysis of this segment data:

01H address of the driver

10H write function code

0100H write data of F1.00

0002H item count of write menu, i.e. two items of F1.00 and F1.01

4034H 16 bits of CRC check code

Example:

Name	Frame format
Set F1.00, F1.01 at 1 and 0.02 respectively	Send frame: 01H 10H 0100H 0002H 04H 0001H 0002H 2E3EH
	Return frame: 01H 10H 0100H 0002H 4034H
Forward and communicate reference frequency at 50HZ	Send frame: 01H 10H 2000H 0002H 04H 0001H 1388H 36F8H
	Return frame: 01H 10H 2000H 0002H 4A08H
Set F1.00 at 1	Send frame: 01H 10H 0100H 0001H 02H 0001H 7750H
	Return frame: 01H 10H 0100H 0001H 0035H



## Communication Protocol

6) 13H read single parameter (including attribute, min. value, max. value)

Inquiry information frame format (Send frame):

Address	01H
Function	13H
Starting data address	00H
	0CH
Number of Data(Byte)	00H
	04H
CRC CHK High	45H
CRC CHK Low	CBH

Analysis of this segment data:

01H address of the driver

13H read function code

000CH start address, equivalent to F0.12 of control panel

0004H register amount

45CBH 16 bits of CRC check code

Inquiry information frame format (Return frame) :

Address	01H
Function	13H
Starting data address	00H
	12H
Data1(2Byte)	13H
	88H
Data2(2Byte)	03H
	22H
Data3(2Byte)	00H
	00H
Data4(2Byte)	13H
	88H
CRC CHK High	28H
CRC CHK Low	31H

## Communication Protocol

Analysis of this segment data:

01H address of the driver

13H write function code

000CH start address, equivalent to F0.12 of control panel

1388H parameter value

0322H attribute value

0000H min. value

1388H max. value

2831H 16 bits of CRC check code

Example:

Name	Frame format
Read parameter value of F0.12	Send frame: 01H 13H 000CH 0001H 85CAH
	Return frame: 01H 13H 02H 1388H B1D2H
Read parameter value + attribute value of F0.12	Send frame: 01H 13H 000CH 0002H C5CBH
	Return frame: 01H 13H 04H 1388H 0322H FCE4H
Read parameter value + attribute value + min. value of F0.12	Send frame: 01H 13H 000CH 0003H 040BH
	Return frame: 01H 13H 06H 1388H 0322H 0000H 628BH
Read parameter value + min. value + max. value of F0.12	Send frame: 01H 13H 000CH 0004H 45CBH
	Return frame: 01H 13H 08H 1388H 0322H 0000H 1388H 2831H

## Communication Protocol

### 5.3 Functions of other Register Address:

function	address	description				
VFD operation status	A000H(1A00H)	byte	bit	meaning		
			Byte1	Bit7	0: no action 1: overload pre-alarm	
		Bit6 ~ Bit5		0: INV_220V 1: INV_380V 2: INV_660V 3: INV_1140V		
		Bit4		0: no action 1: power of save		
		Bit3		0: no action 1: reset		
		Bit2 ~ Bit1		0: no action 1: static tuning 2: dynamic tuning		
		Bit0		0: control panel mode 1: terminal control mode		
		Byte0	Bit7	2: communication control mode 3: reserved		
		VFD operation status	A000H(1A00H)	Byte0	Bit6	0: no action 1: bus voltage is normal
					Bit5	0: no action 1: undervoltage
Bit4	0: no action 1: jog run					
Bit3	0: forward 1: reverse					
Bit2 ~ Bit1	1: Acc 2: Dec 3: constant speed					
Bit0	0: stop status 1: run status					
Read VFD fault code	E000H(1E00H)	Address E000H and 1E00H interchangeable (refer to fault code table and example of read function code 03H)				
Read VFD fault pre-alarm code	E001H(1E01H)	Address E001H and 1E01H interchangeable (refer to example of pre-alarm code, read function code 03H)				
User password check	AD00H(1C00H)	Address AD00H and 1C00H interchangeable (refer to example of write function code 06H)				
Operation limit password check	AD01H(1C01H)	Address AD00H and 1C00H interchangeable (refer to example of write function code 06H)				

## Communication Protocol

### 5.4 Fault Code:

Fault code	Displayed code	Fault information
0000H	—	No fault
0001H	E-01	Overcurrent when accelerating
0002H	E-02	Overcurrent when decelerating
0003H	E-03	Overcurrent at constant speed
0004H	E-04	Overvoltage when accelerating
0005H	E-05	Overvoltage when decelerating
0006H	E-06	Overvoltage at constant speed
0007H	E-07	Bus undervoltage
0008H	E-08	Motor overload
0009H	E-09	Driver overload
000AH	E-10	Driver of load
000BH	E-11	Function module fault
000CH	E-12	Input phase loss
000DH	E-13	Output phase loss or current unbalance
000EH	E-14	Short circuit of output to earth
000FH	E-15	Heatsink overheat 1
0010H	E-16	Heatsink overheat 2
0011H	E-17	RS485 communication fault
0012H	E-18	Keypad communication fault
0013H	E-19	External device fault
0014H	E-20	Current detection fault
0015H	E-21	Motor tuning fault
0016H	E-22	EEPROM read-write fault
0017H	E-23	Parameters copy fault
0018H	E-24	PID feedback disconnection
0019H	E-25	Voltage feedback disconnection
001AH	E-26	Arrival of operation limit time
001BH	E-27	Coprocessor communication fault
001CH	E-28	Encoder disconnection fault
001DH	E-29	Speed deviation too much
001EH	E-30	Over-speed fault

## Communication Protocol

### 5.5 Pre-alarm Code of the Driver:

Alarm code	displayed	Fault information
0000H	—	No fault
0009H	A-09	Driver overload alarm
0011H	A-17	RS485 communication fault alarm
0012H	A-18	Keypad communication fault alarm
0015H	A-21	Motor tuning alarm
0016H	A-22	EEPROM read-write fault alarm
0018H	A-24	PID feedback disconnection alarm

### 5.6 Control Command Format (see function code 06H example) :

address	bit	meaning
2000H	Bit7 ~ Bit5	reserved
	Bit4	0: no action 1: reset
	Bit3	0: forward 1: reverse
	Bit2 ~ Bit0	100: free stop 011: stop 010: jog run 001: run
2008H (output by pressing position 1 close by pressing position 0)	Bit7 ~ Bit4	reserved
	Bit3	Programmable relay R2 output
	Bit2	Programmable relay R1 output
	Bit1	Open collector output terminal Y2
	Bit0	Open collector output terminal Y1

## Communication Protocol

### 5.7 Parameter Attribute:

bit	meaning		
Bit15	reserved		
Bit14	menu		
Bit13	system		
Bit12	reset to factory defaults		
Bit11	EEPROM		
Bit10 ~ Bit9	"○": 01 "×": 10 "◆": 11 "◇": 00		
Bit8	sign		
Bit7 ~ Bit3	1: 00000 V: 00001 A: 00010 rpm: 00011 HZ: 00100 %: 00110 S: 01000	KHZ: 01100 KW: 01010 om: 01110 ms: 01001 MA: 01011 KM: 01101 CM: 01111	us: 10001 HZ/S: 10000 mh: 10010 C: 10011 m/s: 10100 H: 10101 KWH: 10110
Bit2 ~ Bit0	Decimal point		

### 5.8 Error Code from Slave Response of Abnormal Information:

Error code	description
01H	Invalid function code
02H	Invalid address
03H	Invalid data
04H	Invalid register length
05H	CRC validation error
06H	Parameters can't be changed during running
07H	The changes of parameters are invalid
08H	Control command of host is invalid
09H	Parameter protected by password
0AH	Password error

## Communication Protocol

### 5.9 Communication Address of all Parameters:

Function code	Communication address
F0.00 ~ F0.22	0000H ~ 0016H
F1.00 ~ F1.37	0100H ~ 0125H
F2.00 ~ F2.17	0200H ~ 0211H
F3.00 ~ F3.08	0300H ~ 0308H
F4.00 ~ F4.27	0400H ~ 041BH
F5.00 ~ F5.24	0500H ~ 0518H
F6.00 ~ F6.52	0600H ~ 0634H
F7.00 ~ F7.36	0700H ~ 0724H
F8.00 ~ F8.33	0800H ~ 0821H
F9.00 ~ F9.73	0900H ~ 0949H
FA.00 ~ FA.35	0A00H ~ 0A23H
FB.00 ~ FB.07	0B00H ~ 0B07H
FC.00 ~ FC.28	0C00H ~ 0C1CH
FE.00 ~ FE.15	0E00H ~ 0E0FH
FF.00 ~ FF.22	0F00H ~ 0F16H
d-00 ~ d-57	D000H (1D00H) ~ D039H (1D39H)

#### Notice:

- ◇ In the above examples, the driver address is 01, which makes it better for illustration; when the driver is slave, the address setting range is 1 ~ 247, and if any data of frame format is changed, the check code needs to be recalculated. The calculating tools of 16bit CRC check code can be download from internet.
- ◇ Initial address of monitor item is D000, each item offset corresponding hexadecimal value based on this address, then plus it with the initial address. For example: the monitor initial item is d-00, the corresponding initial address is D000H (1D00H), now read monitor item d-18, 18-00=18, the corresponding hexadecimal of 18 is 12H, then the read address of d-18 is D000H+12H = D012H (1D00H+12H = 1D12H). Address D000H and 1D00H are interchangeable.
- ◇ Frame format when the slave response information is abnormal: driver address + (80H+function code) + 16bit CRC check code; if the salve return frame is 01H + 83H + 04H + 40F3H, then 01H is slave address, 83H is 80H+03H indicating read error, 04H is invalid data length, 40F3H is 16bit CRC check code.

## 6 Troubleshooting

### 6.1 Fault information and Troubleshooting

Any abnormality occurs during operation, the driver will lock PWM output immediately and enter protection status. Meanwhile, the keypad will display function codes indicating the current fault, and the ALM indicator light will be on.

Follow the method described in Table 6-1 to check the fault cause and conduct according actions. If the problem remains, contact us directly.

Fault code	Fault descriptions	Possible reasons	Actions
E-01	Over-current in Acc process	Too short Acc time (including tuning process)	Prolong the Acc time
		Restart the rotating motor	Start after setting as DC brake, or rotational speed tracking start
		Drive power is too small	Select a higher power drive
		V/F curve is not suitable	Adjust V/F curve or torque boost
E-02	Over-current in Dec process	Too short Dec time (including tuning process)	Prolong the Dec time
		Too low driver's power	Select the drive with large capacity
		the load inertia is too high	Connect suitable braking resistor or braking unit
E-03	Over-current in constant speed operation	Low network voltage	Check the power supply
		Sudden change or abnormal of load	Check the load or reduce the change of the load
		Too low driver's power	Select the driver with larger capacity
E-04	Over voltage in Acc process	Abnormal supply voltage (including tuning process)	Check the power supply
		The driver is restarted with a rotating motor	Start after setting as DC braking, or rotational speed tracking start
E-05	Over voltage in Dec process	Special potential energy load	Connect suitable braking resistor or braking unit
		Too short Dec time (including tuning process)	Prolong the Dec time
		The load inertia is too high	Connect suitable braking resistor or braking unit
		Abnormal of supply voltage	Check the power supply

## 6.1 Fault information and Troubleshooting

Fault code	Fault descriptions	Possible reasons	Actions
E-06	Over voltage in constant-speed operating	Abnormal of supply voltage	Check the power supply
		Special potential energy load	Connect suitable braking resistor or braking unit
E-07	Bus undervoltage	Abnormal of supply voltage or disconnecting of contactor (relay)	Check supply voltage or seek help from manufacturer
E-08	Motor overload	Improper setting of V/F curve or torque boost	Adjust V/F curve and torque boost value
		Low network voltage	Check network voltage
		Motor blocked or load sudden change	Check load
		Incorrect setting of motor overload protection factor	Correct the setting
E-09	Driver overload	Improper setting of V/F curve or torque boost	Adjust V/F curve and torque boost value
		Low network voltage	Check network voltage
		Too short Acc time	Prolong Acc time
		Too heavy load	Select the driver with larger power
E-10	Of load	Output current lower than of-load detection	Check load
E-11	Function module fault	Short circuit or grounded of driver output	Check motor wiring
		Instantaneous over current of driver	Refer to actions of over current
		Obstruction of damage of ventilation channel	Clear the ventilation channel or replace the fan
		control board abnormal or interference serious	Seek help from manufacturer
		Power device damage	Seek help from manufacturer
E-12	Input phase loss	Phase loss of power supply	Check power supply and wiring
E-13	Output phase loss or current imbalance	Output phase failure among phase U, V, W	Check the driver's output wiring

## 6.1 Fault information and Troubleshooting

Fault code	Fault descriptions	Possible reasons	Actions
E-14	Short trouble of output to ground	reserved	reserved
E-15	Heatsink overheat 1	Ambient over-temperature	Lower the ambient temperature
		Fan damage	Replace the fan
E-16	Heatsink overheat 2	Obstruction of ventilation channel	Clear the ventilation channel
E-17	RS485 communication failure	Mismatching with baud rate of host PC	Adjust the baud rate
		RS485 channel interference	Check whether the communication wiring is shield, whether the wiring is correct; consider connecting filter capacitor if necessary .
		Communication timeout	retry
E-18	Keypad communication fault	Connecting line between keypad and control board is damaged	Replace the connecting line
E-19	External device fault	Input terminal of external device fault is closed	Disconnect the terminal and clear the faults (check the fault cause)
E-20	Current detection fault	Hall device or amplification circuit fault	Seek help from manufacturer
		Auxiliary power supply is damaged	
		Hall or power board wiring is bad contact	
E-21	Motor tuning fault	Wrong setting of motor parameters	Reset the motor parameter
		Mismatching of power specification between driver and motor	Seek help from manufacturer
		Tuning timeout	Check motor wiring
E-22	EEPROM R/W fault	EEPROM fault	Seek help from manufacturer



## 6.1 Fault information and Troubleshooting

Fault code	Fault descriptions	Possible reasons	Actions
E-23	Parameter copy fault	Upload fault of the driver parameter to operation panel	Check wiring of operation panel
		Download fault of parameter from operation panel to the driver	Check wiring of operation panel
		Parameter download without upload in advance	Upload parameters frst, then download
E-24	PID feedback disconnecting	PID feedback wire is loosen	Check feedback wiring
		Feedback value lower than disconnection detection value	Adjust detection input threshold
E-25	Voltage feedback disconnecting	Feedback value lower than disconnection detection value	Adjust detection input threshold
E-26	Arrival of operation limit time	Arrival of operation limit time	Seek help from agent
E-27	Co-processor communication fault	reserved	reserved
E-28	Encoder disconnecting	reserved	reserved
E-29	Large deviation of speed	reserved	reserved
E-30	Overspeed fault	reserved	reserved
E-31	reserved	reserved	reserved
E-32	water shortage protection	water shortage protection	check if water pressure is under normal range

Table 6-1 Fault Diagnosis and Troubleshooting

## 6.2 Abnormal Phenomena Solution

During the driver operation, the common abnormal phenomena and solving actions are as showed in Table 6-2.

Phenomena	Possible reasons of fault and actions to take	
motor not running	LED no display	Check whether there is power failure, or phase loss of input power, check if the power line is connected correctly.
	LED no display, but the internal charging indicator is on	Check if there is problems with wiring or socket related to keypad. Measure the voltage of internal control source to check if the switching power supply is functioning well. If not, check its inlet wire, start oscillation and stabilivolt to see if they works well.
	Motor droning	The motor load is too much. Reduce the load.
	No abnormal phenomena	Check if it is in trip status or hasn't reset after tripping, check whether it is in restart status after power down, whether the keypad is reset, whether it is in program running status, multi-speed operation status, some specific operation status or non-operation status. Try recovering factory set. Check whether the running command is sent. Check whether the operation frequency is set at 0.
The motor can not Acc/Dec successfully	Improper setting of Acc/Dec time. Increase the value of Acc/Dec time.	
	The current limit is set too low. Increase the value.	
	Over-voltage protection action during decelerating. Increase the decelerating time.	
	Improper setting of carrier frequency, too much load may cause oscillation.	
	The load is too heavy, and the torque is not enough. Increase torque boost value in V/F mode. If not working, switch to auto torque boost mode, and the motor parameters should be in consistent with the actual value. If still not working, switch to fux vector control mode, and check the motor parameters and actual values to see if they are matched, meanwhile tune the motor parameters.	
	Mismatching of motor power and driver power. Set the motor parameters at actual value. One driver for several motor. Please change the torque boost mode to manual mode.	

## 6.2 Abnormal Phenomena Solution

Phenomena	Possible reasons of fault and actions to take
The motor can rotate, but speed regulation can't be realized.	Improper setting of upper and lower limit of frequency
	The frequency is set too low, or the frequency gain is set too low
	Check whether the speed adjustment mode is in consistent with frequency setting
	Check whether the load is too heavy, whether it is in overvoltage stalled state or overcurrent limiting state.
Speed changing during motor running	Frequent fluctuation of load. Decrease the changing
	Serious mismatching of rated value of the driver and motor. Set the motor parameters as actual value. Frequency setting potentiometer is in bad connect or the frequency setting signal is in fluctuation. Switch to digit setting mode or increase filter time constant of analog input signal.
The rotation direction of motor is in reverse	Adjust phase sequence of output terminal U, V, W
	Set the running direction as reverse (F0.21=1)
	Caused by phase loss of output. Check the motor wiring immediately.

Table 6-2 Common Abnormal Phenomena and Counteractions

## 7 Maintenance

### 7.1 Routine Maintenance

Many factors such as ambient temperature, humidity, smog, internal component aging will give rise to the occurrence of potential faults. Therefore, it is necessary to conduct routine and periodic maintenance during storage or using of the driver.

When the driver operates normally, please check if there are the following items:

- ◇ abnormal sound or vibration of the motor;
- ◇ abnormal heat producing from the driver or motor;
- ◇ high ambient temperature;
- ◇ whether the load current is as usual;
- ◇ whether the cooling fan of the driver runs normally.

### 7.2 Periodic Maintenance

To maintain a long-term normal operation, it is necessary to conduct periodic maintenance according to the working life of internal electronic components. The working life varies with the operation condition. The following table is for reference.

part	normal working life
Cooling fan	2 ~ 3 years
Electrolytic capacitor	4 ~ 5 years
PCB	5 ~ 8 years

## 7.2 Periodic Maintenance

You should check the driver every 3 months or 6 months according to the actual environment, thus could lower fault risks and maintain a long-term stable operation.

General Inspection:

- ◇ whether screws of control terminals are loose. If so, tighten them with a screwdriver;
- ◇ whether the main circuit terminals are properly connected; whether the cable or copper bar joints and screws are over heated;
- ◇ whether the power cables and control cables are damaged, check especially for any wear on the cable insulation;
- ◇ whether the connecting of power cable and cold pressing joint is loose, whether the insulating tapes around the joint are aged or stripped;
- ◇ clear the dust on PCBs and air ducts, and take anti-static measure;
- ◇ before performing insulation tests to the driver, dismantle the wiring between the driver and the power supply, the driver and motor, and all main circuit input/output terminals should be short-circuited with conductors. Then proceed insulation test to the ground. Please use qualified 500V Mega-Ohm-Meter (or with corresponding voltage shift of insulation tester); please do not use faulted meter. Insulation test of single main circuit terminal to ground is prohibited, or the driver can be damaged. After testing, remember to dismantle all the wire that short-circuit main circuit terminals.
- ◇ if performing insulation test to the motor, be sure to disconnect the cables between the driver and it. Otherwise, the driver might be damaged.

## Appendix 1: Parameters for Photovoltaic Pumps Special Use

Function Code	Name	Set Range	Factory Default
F0.07	Main frequency source A	10: MPPT 开启	10
FD.00	Special function of software	0: General function 1: Solar use for pump 2: constant pressure water supply use	1
FD.01	MPPT upper limit voltage	380V: [Fd.01] ~ 1000 537V 220V: [Fd.01] ~ 500 311V	Depending on model
FD.02	MPPT lower limit voltage	380V: 0 ~ [Fd.00] 350V 220V: 0 ~ [Fd.00] 200V	Depending on model
FD.03	Lowest running frequency when yielding water	0.00Hz ~ [F0.16]	20
FD.04	Water shortage detection current ratio corresponding to no-load current	80.0 ~ 300.0%* [F2.10]	150.0
FD.05	Water shortage detection time	0 ~ 250s	10
FC.06	Auto reset times for lacking water fault	0 ~ 100 the setting value of 100 means unlimited times	0
FC.07	Auto restart interval for lacking water detection	0.1 ~ 6000.0min	20.0

## Appendix 1: Parameters for Photovoltaic Pumps Special Use

Photovoltaic pump control process

- ◇ The corresponding relationship between DC bus voltage and output frequency

If that bus voltage (d-12) is higher than the set value of the MPPT upper operating voltage (Fd.01), run at the maximum frequency; if it is lower than the set value of the MPPT upper operating voltage (Fd.01), run at the frequency obtained at the frequency (the bus voltage/MPPT upper operating voltage) \*; If the bus voltage reaches the MPPT lower operating voltage (Fd.02), run at the lowest operating frequency of the efuent (Fd.03).

- ◇ Operate process

First initialize the parameters. (FE.13=2) , when setting Fd.00=1 (photovoltaic pump) , F0.07、Fd.01 ~ Fd.05、FC.06、FC.07 will be default set as above parameter table; Secondly, the relevant parameters are set according to the needs of the site.

Detection of Water shortage in Photovoltaic pump and treatment of Water shortage Fault

- ◇ Detection of Water shortage Fault of Photovoltaic pump:

If the frequency inverter runs above the minimum outlet frequency and the output current is less than the no-load current of the motor (F2.10) \* the ratio of the water shortage detection current of the photovoltaic pump to the no-load current (Fd.04), after the photovoltaic pump water shortage detection time (Fd.05), the inverter reports the water shortage fault E-32.

- ◇ Treatment of Water shortage Fault of Photovoltaic pump

If the water shortage fault E-32 is reported, and the setting value of FC.06 is not 0, the water shortage fault is automatically reset and restarted after the FC.07 set time. When the set value of FC.06 is 0, E-32 will be reported all the time.

## Appendix 2: 600 Series Guide for Rapid Debugging of Constant-pressure Water Supply

Wiring

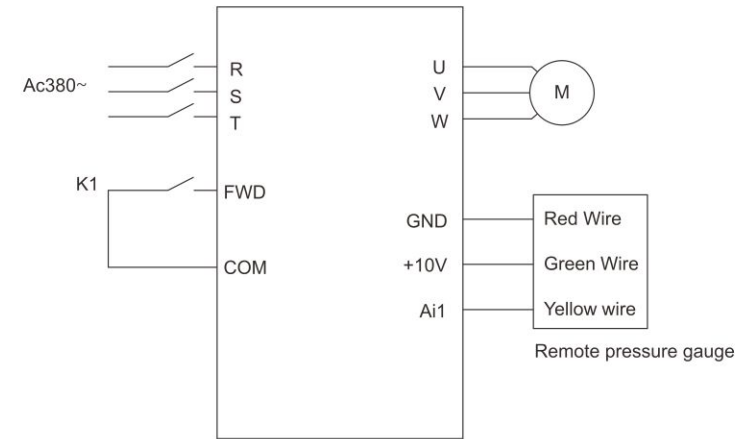

Parameters Setting

F0.05=0	V/F control
F0.06=1	terminal run command
F0.07=8	PID control
F8.01=5	pressure setting(MPa、 Kg)
F8.06=0.5	integral time
F8.13=1	coast to stop in sleep mode
F8.15=100	sleep threshold value
F8.16=90	awake threshold value
F8.17=1.0	sleep delay time
F8.18=1.0	awake delay time
F8.25=10.00	sensor range is 1MPa(10Kg)
F8.26=5.00	set pressure as 5Kg
F8.34=30.0	sleep frequency

## Appendix 3: 610 Series Guide for Rapid Debugging of CNC Machine

### Wiring

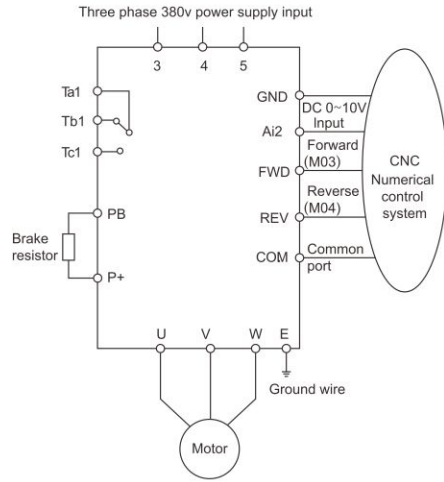

### Parameter setting

Function Code	Name	Set Value	Parameter Description
F0.05	Control mode	2	Open loop current vector control(SVC)
F0.06	Operation command channel	1	Terminal run command channel
F0.07	Main frequency source A	4	Ai2 analog set(DC 0 ~ 10V)
F0.15	Maximum output frequency	100	Maximum output frequency is 100HZ
F0.16	Upper limit frequency	100	Upper limit frequency is 100HZ
F0.19	Acceleration time 1	3	Acceleration time is 3S
F0.20	Deceleration time 1	3	Deceleration time is 3S
F0.21	Running direction	0	Forward
F2.01	Motor's rate power	-	Set according to actual motor parameter
F2.02	Motor's rate freq.	-	Set according to actual motor parameter
F2.03	Motor's rate speed	-	Set according to actual motor parameter
F2.04	Motor's rate voltage	-	Set according to actual motor parameter
F2.16	Motor tuning	-	0: no action; 1: static tuning;

Note: 610 series frequency inverter has been set with the special parameters of CNC machine tools when it leaves the factory. It only needs to align the system speed; if the actual speed and system speed do not correspond, set the F0.15 and F0.16 these two parameters.

### INVERTER WARRANTY CARD

USER NAME:	
ADD:	
POSTAL CODE:	CONTACT PERSON:
TELEPHONE:	FAX:
SERIAL NUMBER:	
POWER :	TYPE:
CONTACT NO. :	PURCHASE DATE:
SERVICE COMPANY:	
CONTACT PERSON:	TELEPHONE:
TECHNICIAN:	TELEPHONE:
REPAIR DATE:	
USER COMMENT:	<input type="checkbox"/> GOOD <input type="checkbox"/> NORMAL <input type="checkbox"/> BAD
NOTES :	
USER SIGNATURE:	DATE:
COMPANY SERVICE RECORD:	
OTHERS :	